

15073xx1

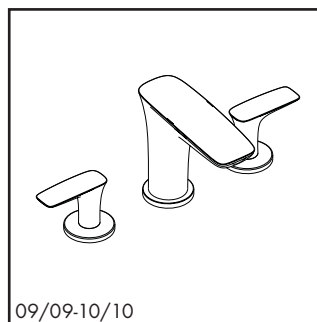

15073xx1

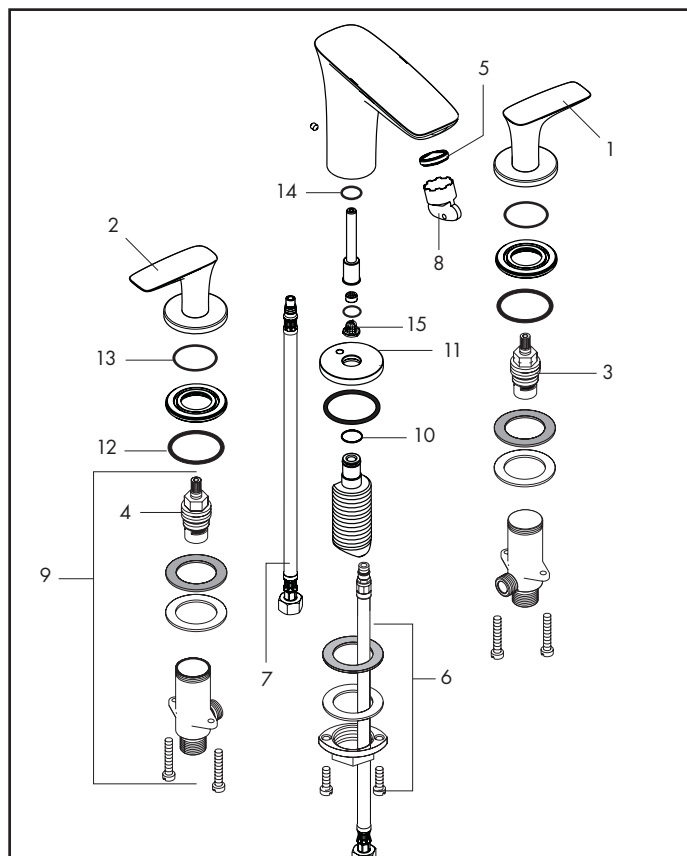
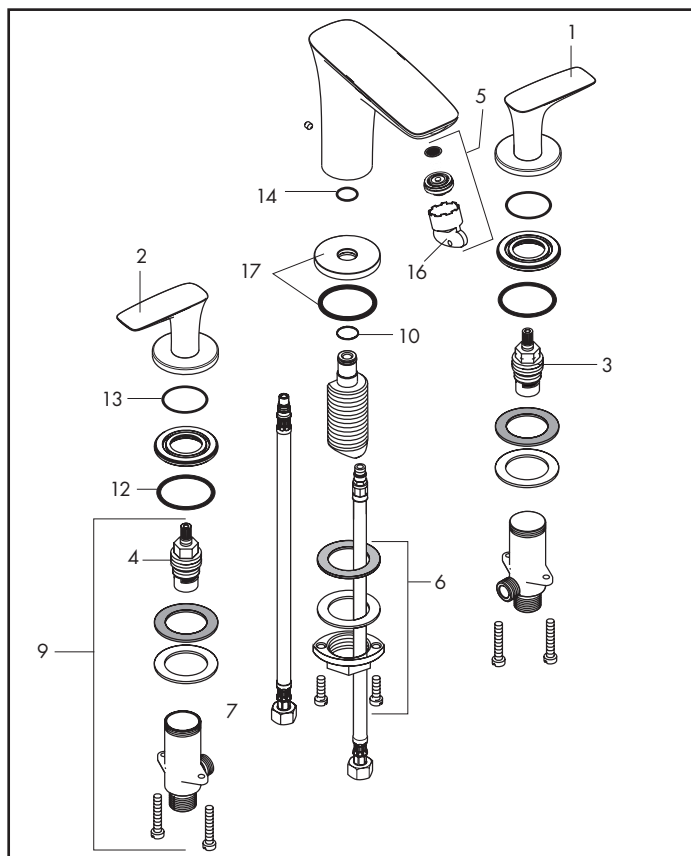

Pos.	Description	Description	Denominación	No./Nr./N°	PG
1	cold handle	poignée eau froide	manija agua fría	95271xx0	1 19*
2	hot handle	poignée eau chaude	manija agua caliente	95270xx0	1 19*
3	cold cartridge	mécanisme eau froide	montura augua fría	94009000	1 10
4	hot cartridge	mécanisme eau chaude	montura agua caliente	94008000	1 10
5	aerator	aérateur cpl	airedador completo	95282000	1 6
6	fixing set	fixation cpl.	set de fijación	13961000	1 7
7	connection hose 18"	flexible de raccordsments 18"	conexión flexible 18"	96321001	1 9
8	aerator service key	clé de montage	llave de montaje	95290000	1 99
9	complete valve	robinet d'arrêt cpl.	válvula completa	97357001	1 15
10	11 x 2 o-ring	joint torique 11 x 2	junta toroidal 11 x 2	98127000	set 1
11	escutcheon	rosace	florón	97505000	1 12*
12	40 x 3 o-ring	joint torique 40 x 3	junta toroidal 40 x 3	92634000	1 99
13	32 x 2.5 o-ring	joint torique 32 x 2.5	junta toroidal 32 x 2.5	96364000	1 7
14	18 x 2.5 o-ring	joint torique 18 x 2.5	junta toroidal 18 x 2.5	98139000	1 1
15	filter	filtre	filtro	95291000	set 6
16	aerator service key	clé de montage	llave de montaje	95290000	1 99
17	escutcheon	rosace	florón	95787000	1 99

Metris® S

3-Hole lavatory faucet / Robinet grande ecartement / Batéria americana para lavabo

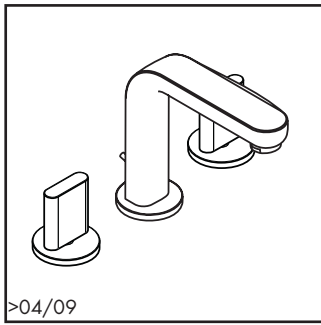

31063xx1

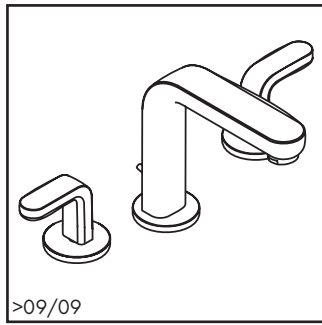

31067xx1

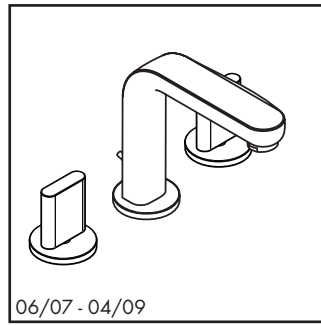

31063xx1

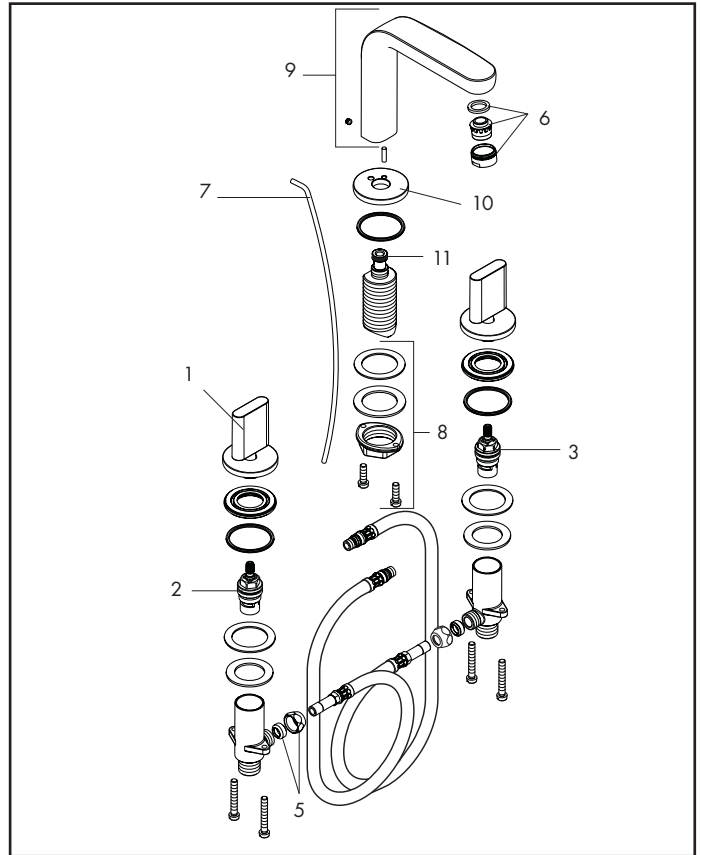
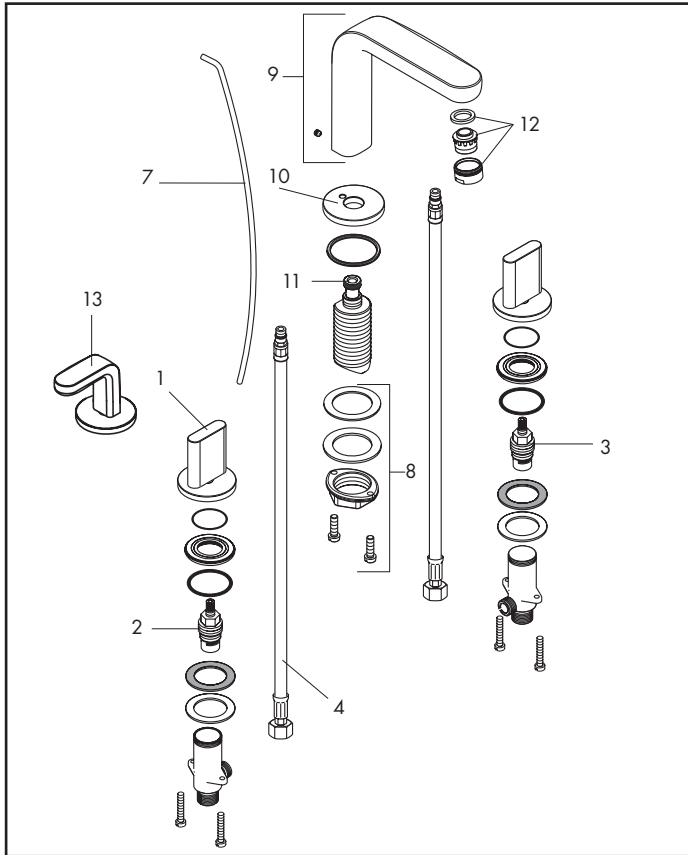

Pos.	Description	Description	Denominación	No./Nr./N°	PG
1	handle	poignée	manija	97502xx0	1 13*
2	hot cartridge	mécanisme d' eau chaude	montura agua caliente	94009000	1 10
3	cold cartridge	mécanisme d' eau froide	montura agua fría	94008000	1 10
4	connection hose 18"	flexible de raccordement 18"	conexión flexible 18"	94071001	1 9
5	3/8" compression fittings (pair)	raccord à bague sertie 3/8" (2 pièces)	tueras grifería 3/8" (2 pieza)	88513000	set 4
6	aerator	aérateur	aireador	13085xx0	1 4*
7	pull rod	tirette	tirador	96657xx0	1 4*
8	spout mounting kit	fixation	set de fijación	13961000	1 7
9	spout	bec	caño	97504xx0	1 19*
10	spout escutcheon	rosace pour bec	embellecedor caño	97505xx0	1 12*
11	O-ring 11x2	joint torique 11x2	junta toroidal 11x2	98127000	set 1*
12	aerator	aérateur	aireador	88744xx0	1 8*
13	handle	poignée	manija	98827xx0	1 10*
	pop-up drain, see p. 4.171	vidage lavabo voir p. 4.171	vaciadores ver p. 4.171	94159xx0	1 14*

Metris® C

3-Hole lavatory faucet / Robinet grande ecartement / Batéria americana para lavabo

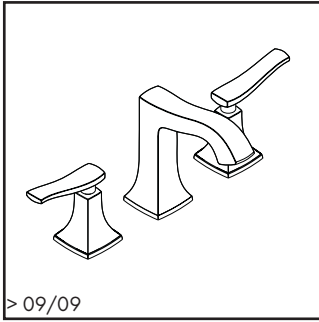

> 09/09

31073xx1

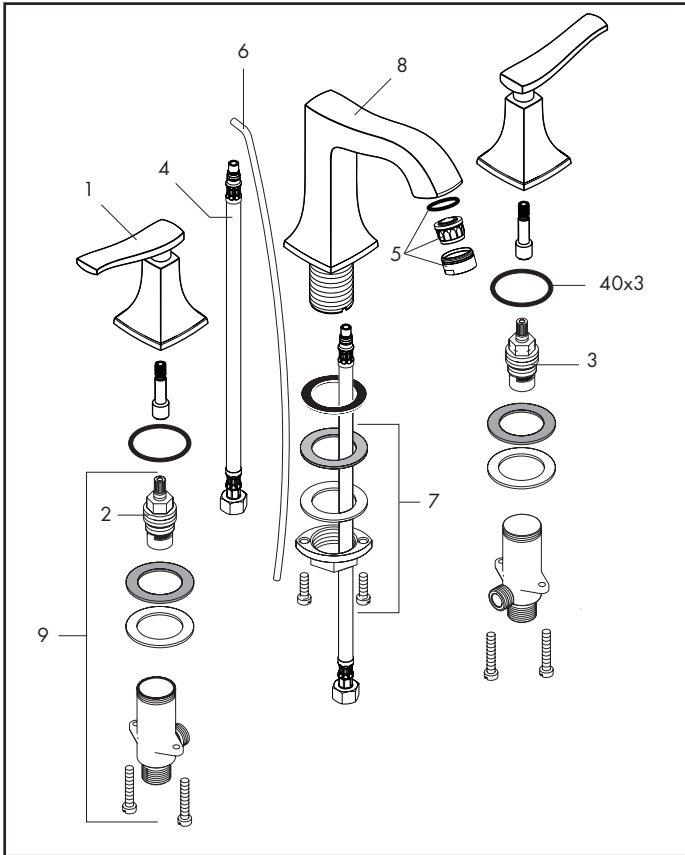

Pos.	Description	Description	Denominación	No./Nr./N°	PG
1	handle	poignée	manija	31292xx1	1 99
2	hot cartridge	mécanisme d' eau chaude	montura agua caliente	94009000	1 10
3	cold cartridge	mécanisme d' eau froide	montura agua fría	94008000	1 10
4	connection hose 18"	flexible de raccordement 18"	conexión flexible 18"	96321001	1 8
5	aerator	aérateur	aireador	88744xx0	1 8*
6	pull rod	tirette	tirador	96657xx0	1 4*
7	spout mounting kit	fixation	set de fijación	13961000	1 7
8	spout	bec	caño	95394xx0	1 99
9	valve	robinet d'arrêt	válvula completa	97357001	1 15
	pop-up drain, see p. 4.171	vidage lavabo voir p. 4.171	vaciadores ver p. 4.171	94159xx0	1 14*

4.70
6/2011

xx = Please see p. 4.1 for finish codes / *PG is for Chrome only. See the index for other finishes.
 xx = Description des codes couleur page 4.1 / *PG concerne Chromé seulement. Pour les autres, voir dans la liste des références.
 xx = Para el código de acabados ver p. 4.1 / *La PG vale para Cromado solo. Ver el índice para las otras superficies.



Talis® S

3-Hole lavatory faucet / Robinet grande ecartement / Bat eria americana para lavabo

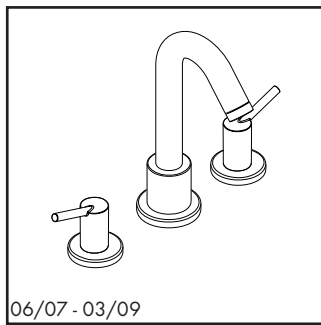

32310xx1

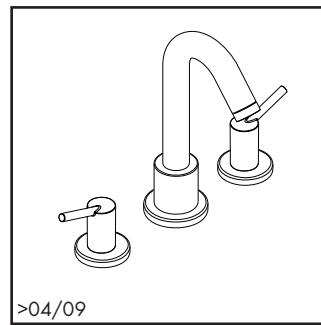

32310xx1

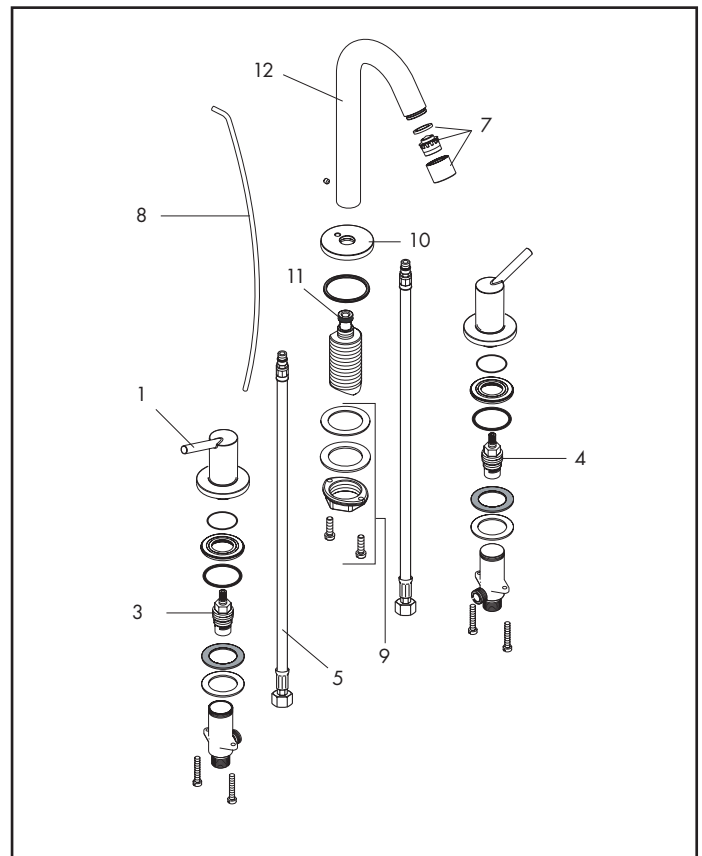
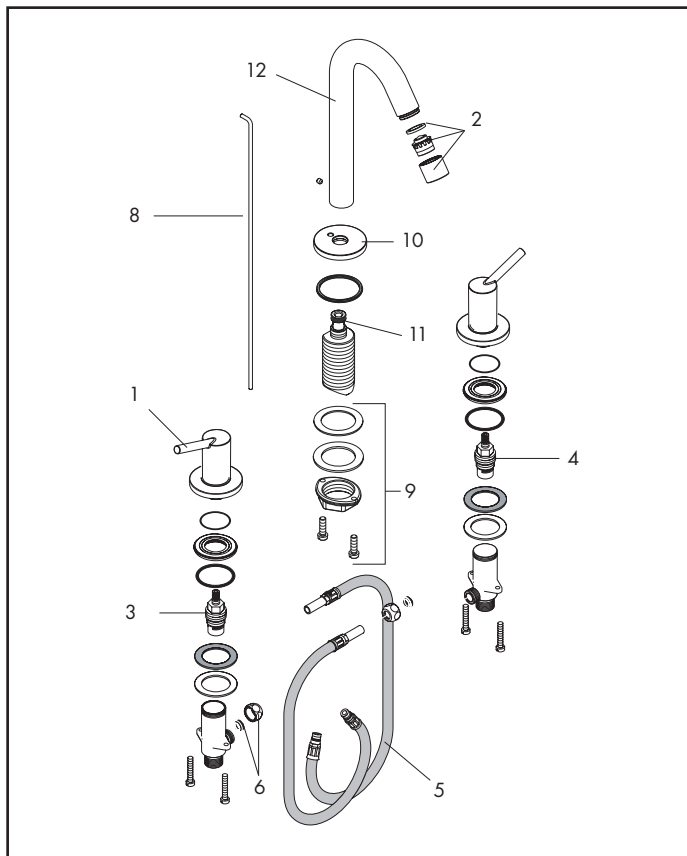

Pos.	Description	Description	Denominaci3n	No./Nr./N°	PG
1	handle	poign�e	manija	95338xx0	1 13*
2	aerator	a�rateur	aireador	94010xx0	1 10*
3	hot cartridge	m�canisme d' eau chaude	montura agua caliente	94009000	1 10
4	cold cartridge	m�canisme d' eau froide	montura agua fr�a	94008000	1 10
5	connection hose 18"	flexible de raccordement 18"	conexi3n flexible 18"	94071001	1 9
6	3/8 compression fittings (pair)	raccord � bague sertie 3/8 (2 pi�ces)	tuercas grifer�a 3/8 (2 pieza)	88513000	set 4
7	aerator	a�rateur	aireador	95455xx0	1 99
8	pull rod	tirette	tirador	96657xx0	1 4*
9	spout mounting kit	fixation	set de fijaci3n	13961000	1 7
10	spout escutcheon	rosace pour bec	embellecedor ca�o	97505xx0	1 12*
11	o-ring 11x2	joint torique 11x2	junta toroidal 11x2	98127000	set 1*
12	spout	bec	ca�o	95339xx0	1 17*
	pop-up drain, see p. 4.171	vidage lavabo voir p. 4.171	vaciadores ver p. 4.171	94159xx0	1 14*

hansgrohe

xx = Please see p. 4.1 for finish codes / *PG is for Chrome only. See the index for other finishes.

xx = Description des codes couleur page 4.1 / *PG concerne Chrom  seulement. Pour les autres, voir dans la liste des r f rences.

xx = Para el c3digo de acabados ver p. 4.1 / *La PG vale para Cromado solo. Ver el indice para las otras superficies.

4.71
6/2011

Talis® C

3-Hole lavatory faucet / Robinet grande ecartement / Batéria americana para lavabo

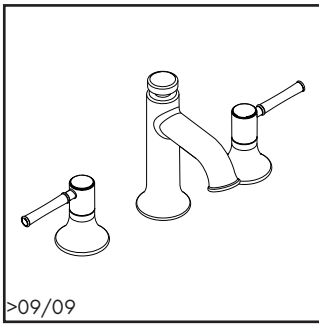

>09/09

14113xx1

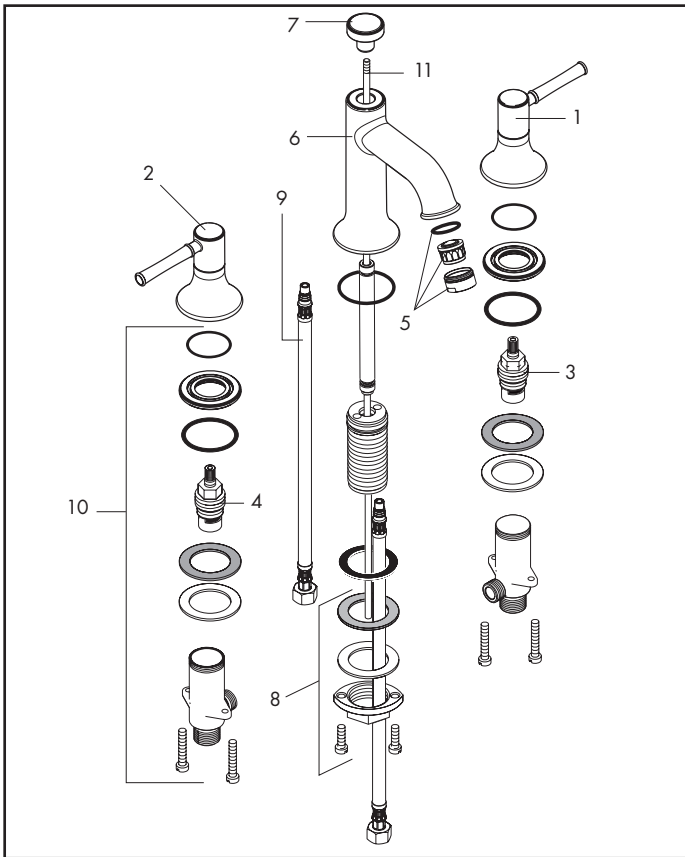

Pos.	Description	Description	Denominación	No./Nr./N°	PG
1	cold handle	poignée eau chaude	manija agua caliente	98524xx0	1 99
2	hot handle	poignée eau froide	manija agua fría	98525xx0	1 99
3	cold cartridge	mécanisme d' eau froide	montura agua fría	94008000	1 10
4	hot cartridge	mécanisme d' eau chaude	montura agua caliente	94009000	1 10
5	aerator	aérateur	aireador	88744xx0	1 8*
6	spout	bec	caño	98526xx0	1 99
7	pull rod knob	bouton d'inverseur	tirador inversor	98528xx0	1 99
8	fixing set	fixation	set de fijación	13961000	1 7
9	connecting hose	flexible de raccordement	conexión flexible	96321001	1 9
10	valve	robinet d'arrêt	válvula completa	97357001	1 15
11	pull rod	tirette	tirador	95128xx0	1 11*
	pop-up drain, see p. 4.171	vidage lavabo voir p. 4.171	vaciadores ver p. 4.171	88509xx0	1 12*

4.72
6/2011

xx = Please see p. 4.1 for finish codes / *PG is for Chrome only. See the index for other finishes.
 xx = Description des codes couleur page 4.1 / *PG concerne Chromé seulement. Pour les autres, voir dans la liste des références.
 xx = Para el código de acabados ver p. 4.1 / *La PG vale para Cromado solo. Ver el índice para las otras superficies.

hansgrohe

Focus® S

3-Hole lavatory faucet / Robinet grande ecartement / Batéria americana para lavabo

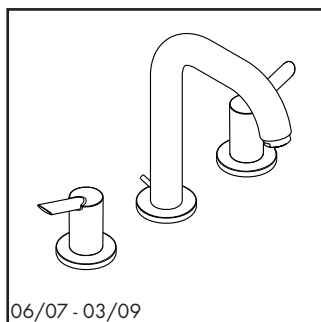

06/07-03/09

31730001

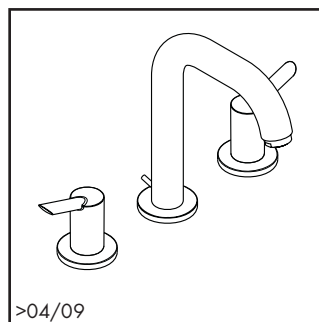

>04/09

31730001

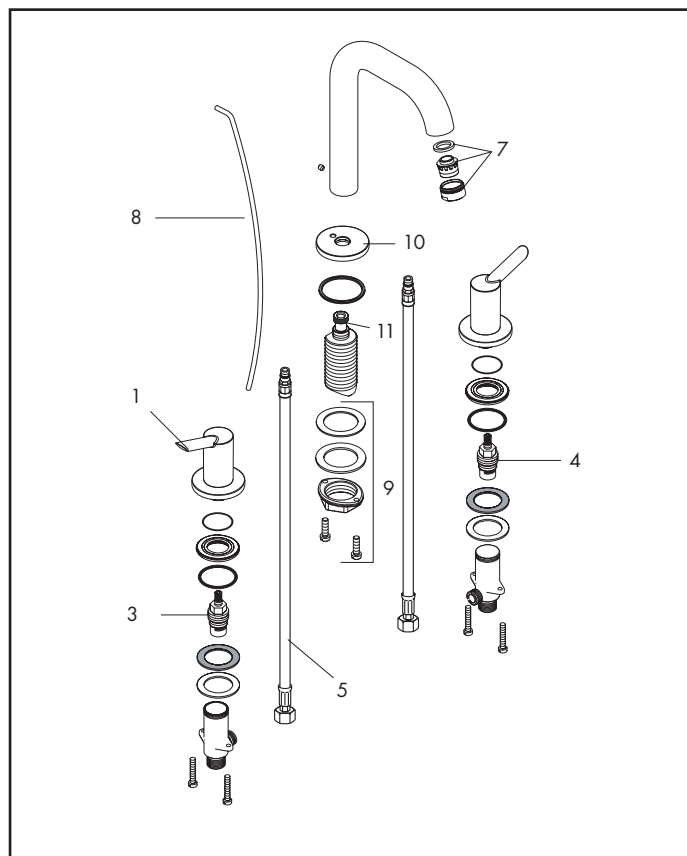
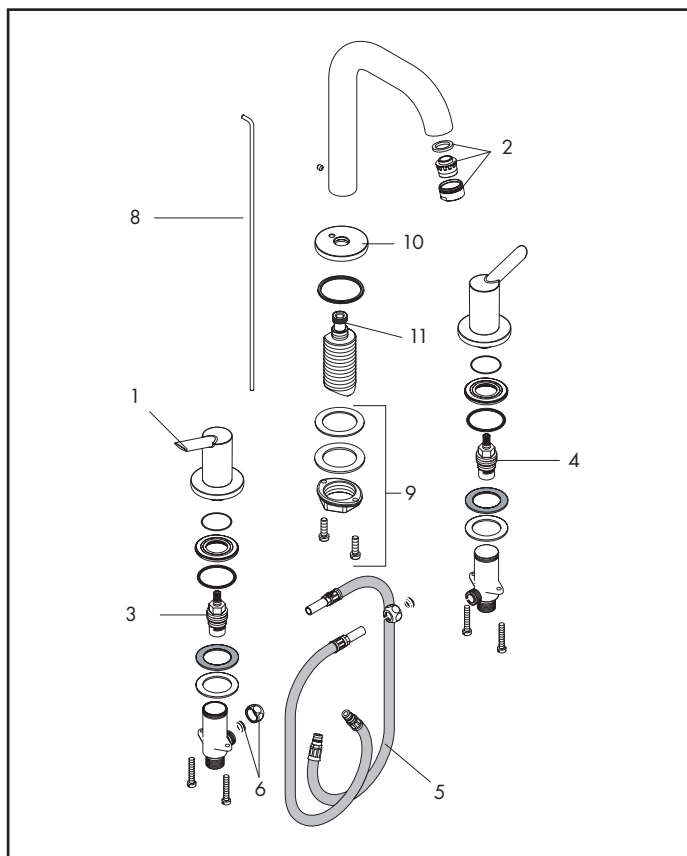

Pos.	Description	Description	Denominación	No./Nr./N°	PG
1	handle	poignée	manija	95453001	1 99
2	aerator	aérateur	aireador	13912xx0	1 4*
3	hot cartridge	mécanisme d' eau chaude	montura agua caliente	94009000	1 10
4	cold cartridge	mécanisme d' eau froide	montura agua fría	94008000	1 10
5	connection hose 18"	flexible de raccordement 18"	conexión flexible 18"	94071001	1 9
6	3/8 compression fittings (pair)	raccord à bague sertie 3/8 (2 pièces)	tuercas grifería 3/8 (2 pieza)	88513000	set 4
7	aerator	aérateur	aireador	88744xx0	1 8*
8	pull rod	tirette	tirador	96657xx0	1 4*
9	spout mounting kit	fixation	set de fijación	13961000	1 7
10	spout escutcheon	rosace pour bec	embellecedor caño	97505xx0	1 12*
11	o-ring 11x2	joint torique 11x2	junta toroidal 11x2	98127000	set 1*
	pop-up drain, see p. 4.171	vidage lavabo voir p. 4.171	vaciadores ver p. 4.171	94159xx0	1 14*

hansgrohe

xx = Please see p. 4.1 for finish codes / *PG is for Chrome only. See the index for other finishes.
 xx = Description des codes couleur page 4.1 / *PG concerne Chromé seulement. Pour les autres, voir dans la liste des références.
 xx = Para el código de acabados ver p. 4.1 / *La PG vale para Cromado solo. Ver el índice para las otras superficies.

Solaris® E

3-Hole lavatory faucet / Robinet 3 trous pour lavabo / Batéria americana para lavabo

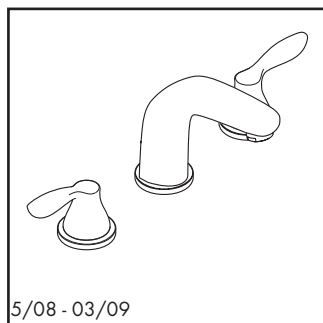

5/08 - 03/09

04169xx0

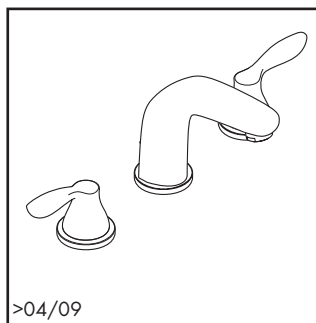

>04/09

04169xx0

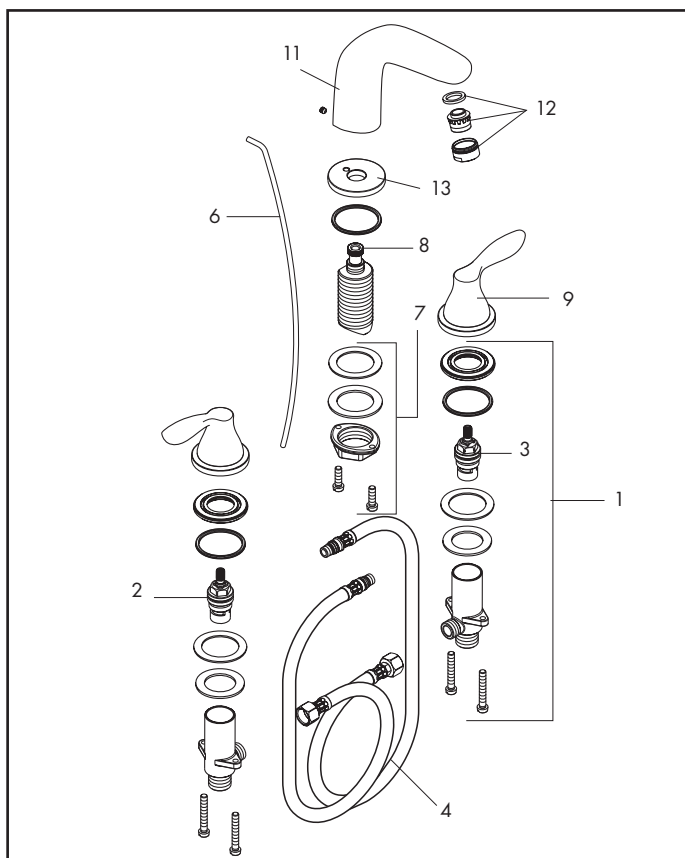
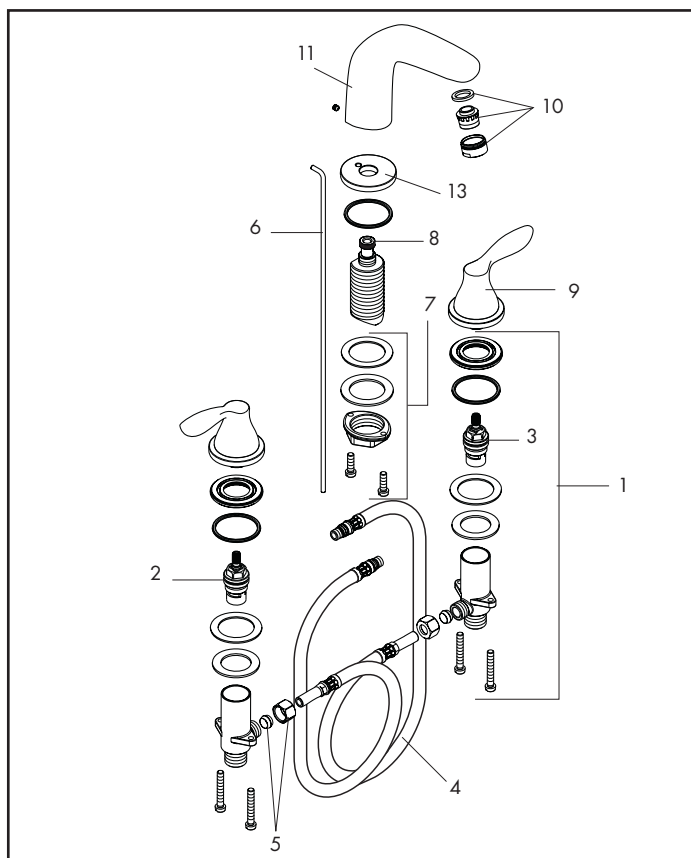

Pos.	Description	Description	Denominación	No./Nr./N°	PG
1	valve	robinet d'arrêt	valvula completa	97357001	1 15
2	hot cartridge	mécanisme eau chaude	montura agua caliente	94009000	1 10
3	cold cartridge	mécanisme eau froide	montura agua fría	94008000	1 10
4	connection hose 18"	flexible de raccordement 18"	conexión flexible 18"	96321001	1 9
5	3/8 compression fittings (pair)	raccord à bague sertie 3/8 (2 pièces)	tuerças grifería 3/8 (2 pieza)	88513000	set 4
6	pull rod	tirette	tirador	96657xx0	1 4*
7	fixing set	fixation	set de fijación	13961000	1 7
8	O-ring 11x2	joint torique 11x2	junta toroidal 11x2	98127000	set 1*
9	handle	poignée	manija	95244xx1	1 99
10	aerator	aérateur	aireador	13912xx0	1 4*
11	spout	bec	caño	95247xx1	1 19*
12	aerator	aérateur	aireador	88744xx0	1 8*
13	escutcheon	rosace	florón	95248xx0	1 99
	pop-up drain, see p. 4.171	vidage lavabo voir p. 4.171	vaciadores ver p. 4.171	88509xx0	1 12*

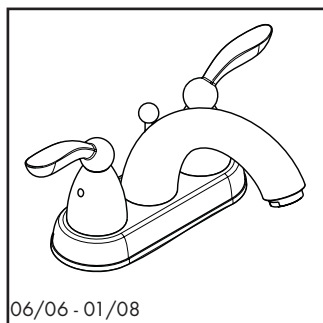

06/06 - 01/08

06434xx0

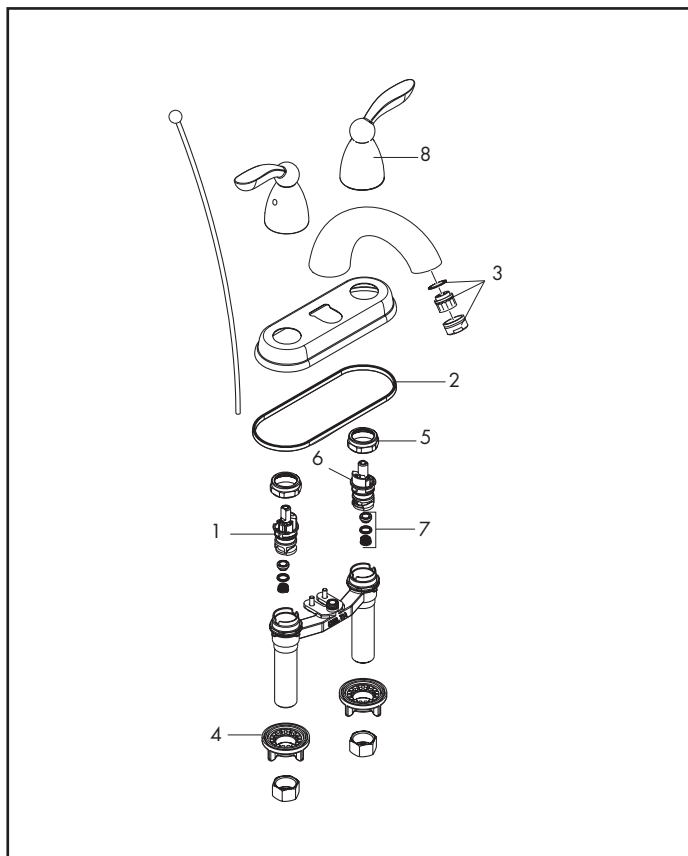

Pos.	Description	Description	Denominación	No./Nr./N°	PG
1	cartridge	cartouche	cartucho	88686000	1 99
2	seal	joint	junta	88687000	1 7
3	aerator	aérateur	aireador	13912xx0	1 4*
4	mounting nut	écrou à six pans	tuerca	88689000	1 99
5	fastening nut	fixation	set de fijación	88690000	1 99
6	1/4 turn stop	Butée 1/4 de tour	parada a un 1/4 de rotación	88691000	1 99
7	seat and spring	set de joints	set de juntas y muelles	88692000	1 99
8	Solaris® handle	poignée Solaris	manija Solaris	88697xx0	1 99
	pop-up drain, see p. 4.171	vidage lavabo voir p. 4.171	vaciadores ver p. 4.171	88509xx0	1 12*

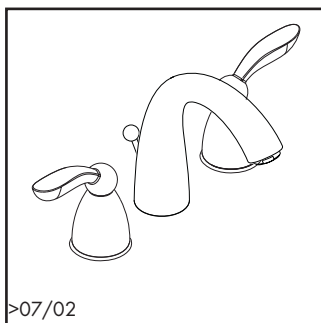

>07/02

06633xx0

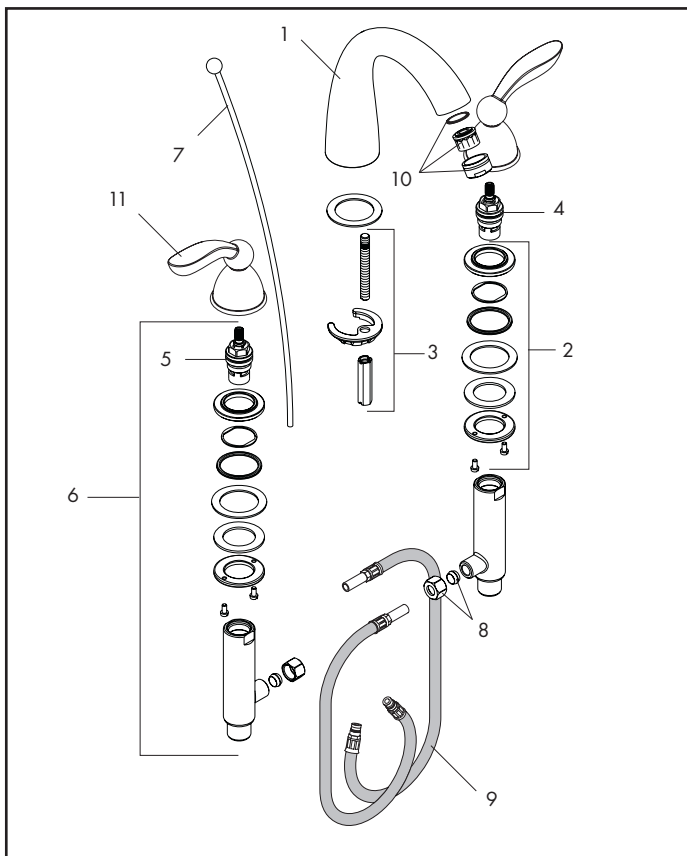

Pos.	Description	Description	Denominación	No./Nr./N°	PG
1	spout	bec	caño	88507xx0	1 16*
2	fixing set	fixation	set de fijación	88511000	1 7
3	fixing set	fixation	set de fijación	88508000	1 6
4	cold cartridge	mécanisme eau froide	montura agua fría	94008000	1 10
5	hot cartridge	mécanisme eau chaude	montura agua caliente	94009000	1 10
6	valve set	robinet d'arrêt	válvula completa	88503000	set 17
7	pull rod and knob	tirette	tirador	88541xx0	1 9*
8	3/8 compression fittings (pair)	raccord à bague sertie 3/8 (2 pièces)	tuercas grifería 3/8 (2 pieza)	88513000	set 4
9	connection hose 18"	flexible de raccordement 18"	conexión flexible 18"	88596000	1 7
10	aerator	aérateur	aireador	13912xx0	1 4*
11	Solaris® handle	poignée Solaris	manija Solaris	88569xx0	1 12*
	pop-up drain, see p. 4.171	vidage lavabo voir p. 4.171	vaciadores ver p. 4.171	88509xx0	1 12*

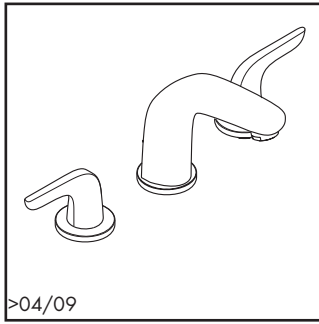

>04/09

04182xx0

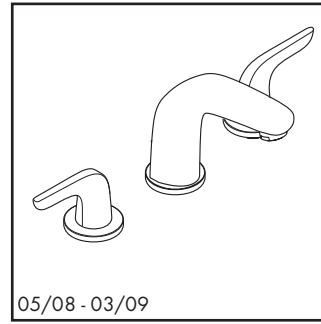

05/08 - 03/09

04182xx0

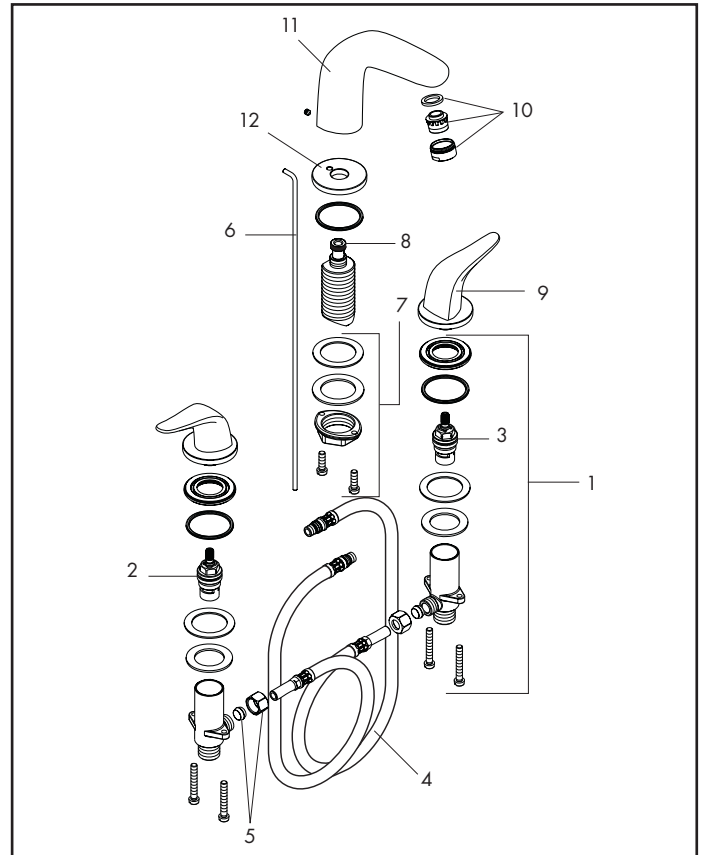
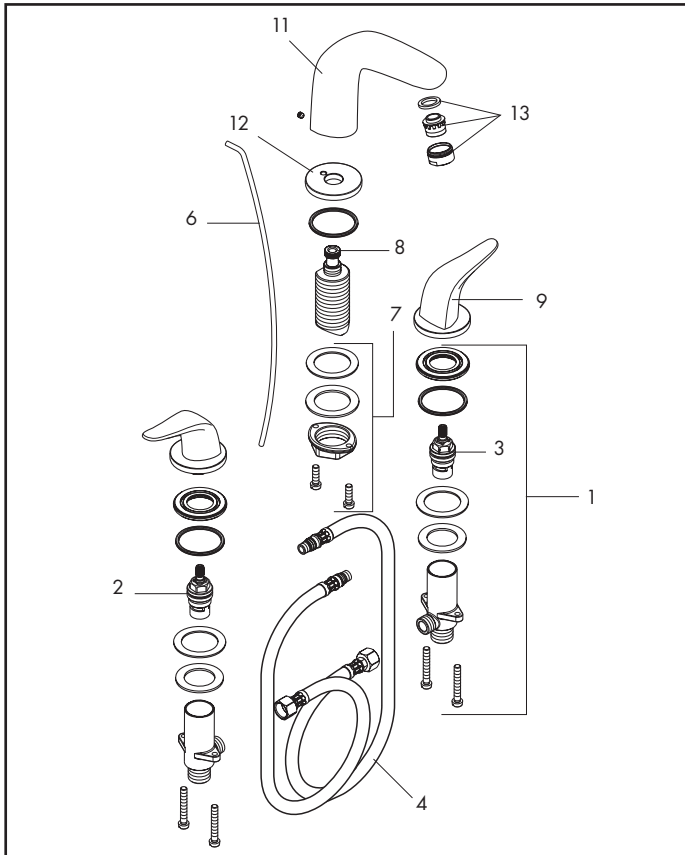

Pos.	Description	Description	Denominación	No./Nr./N°	PG
1	valve	robinet d'arrêt	válvula completa	97357001	1 15
2	hot cartridge	mécanisme eau chaude	montura agua caliente	94009000	1 10
3	cold cartridge	mécanisme eau froide	montura agua fría	94008000	1 10
4	connection hose 18"	flexible de raccordement 18"	conexión flexible 18"	96321001	1 9
5	3/8" compression fittings (pair)	raccord à bague sertie 3/8" (2 pièces)	tuercas grifería 3/8" (2 pieza)	88513000	set 4
6	pull rod	tirette	tirador	96657xx0	1 4*
7	fixing set	fixation	set de fijación	13961000	1 7
8	o-ring 11x2	joint torique 11x2	junta toroidal 11x2	98127000	set 1*
9	handle	poignée	manija	95246xx0	1 99
10	aerator	aérateur	aireador	13912xx0	1 4*
11	spout	bec	caño	95247xx1	1 19*
12	escutcheon	rosace	florón	95248xx0	1 99
13	aerator	aérateur	aireador	88744xx0	1 8*
	pop-up drain, see p. 4.171	vidage lavabo voir p. 4.171	vaciadores ver p. 4.171	88509xx0	1 12*

Metro E

3-Hole lavatory faucet / Robinet grande ecartement / Batéria americana para lavabo

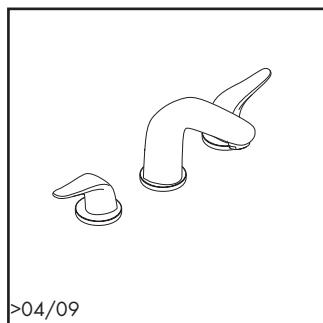

>04/09

04195xx0

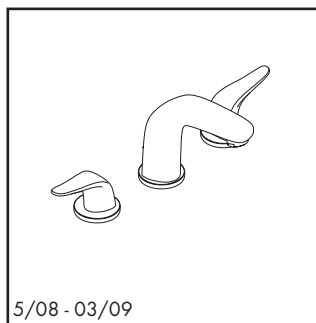

5/08 - 03/09

04195xx0

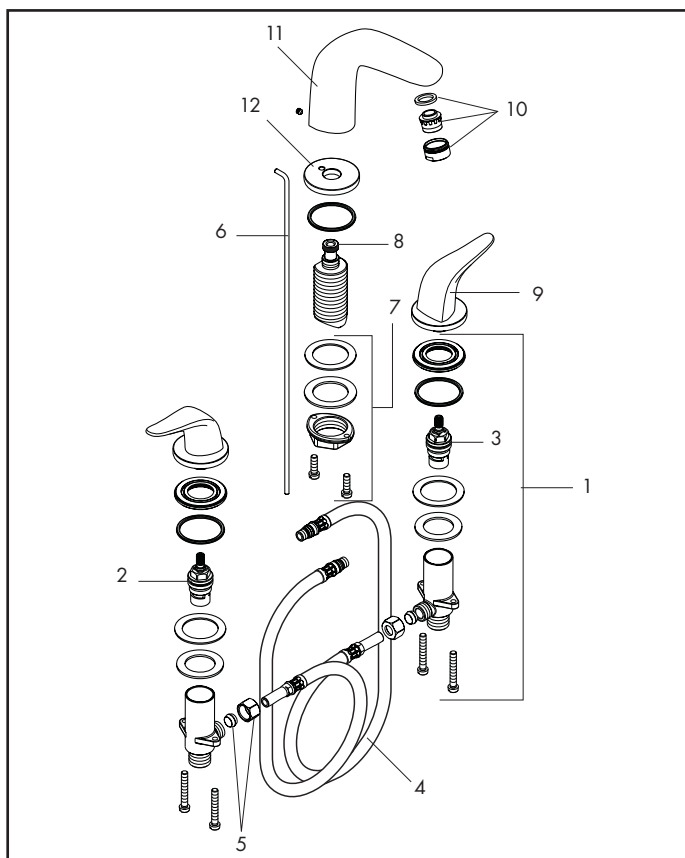
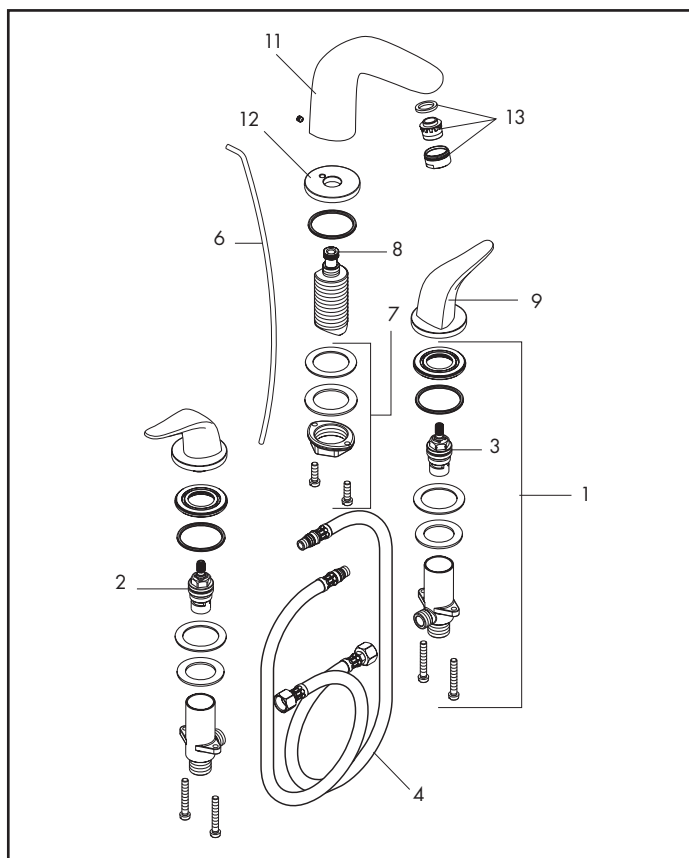

Pos.	Description	Description	Denominación	No./Nr./N°	PG
1	valve	robinet d'arrêt	válvula completa	97357001	1 15
2	hot cartridge	mécanisme eau chaude	montura agua caliente	94009000	1 10
3	cold cartridge	mécanisme eau froide	montura agua fría	94008000	1 10
4	connection hose 18"	flexible de raccordement 18"	conexión flexible 18"	96321001	1 9
5	3/8 compression fittings (pair)	raccord à bague sertie 3/8 (2 pièces)	tuercas grifería 3/8 (2 pieza)	88513000	set 4
6	pull rod	tirette	tirador	96657xx0	1 4*
7	fixing set	fixation	set de fijación	13951000	1 99
8	O-ring 11x2	joint torique 11x2	junta toroidal 11x2	98127000	set 1*
9	handle	poignée Metro E	manija Metro E	95245xx0	1 99
10	aerator	aérateur	aireador	13912xx0	1 4*
11	spout	bec	caño	95247xx0	1 99
12	escutcheon	rosace	florón	95248xx0	1 99
13	aerator	aérateur	aireador	88744xx0	1 8*
	pop-up drain, see p. 4.171	vidage lavabo voir p. 4.171	vaciadores ver p. 4.171	88509xx0	1 12*

Metro

3-Hole lavatory faucet / Robinet grande ecartement / Batéria americana para lavabo

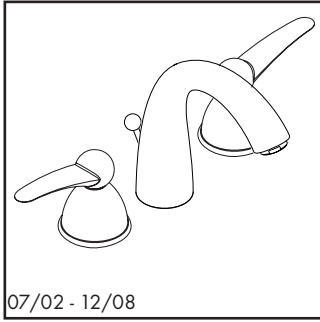

07/02 - 12/08

06653xx0

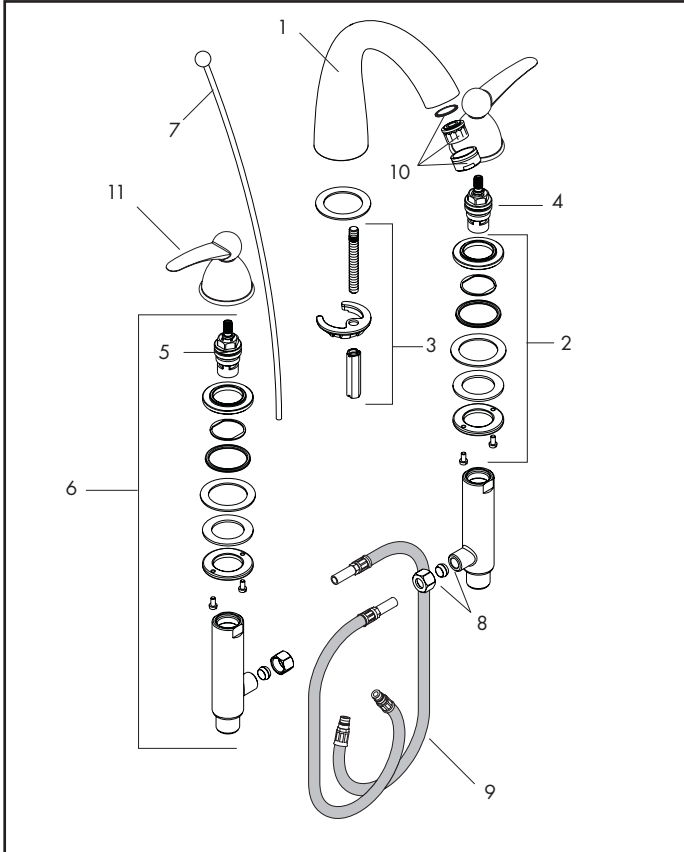

Pos.	Description	Description	Denominación	No./Nr./N°	PG
1	spout	bec	caño	88507xx0	1 16*
2	fixing set	fixation	set de fijación	88511000	1 7
3	fixing set	fixation	set de fijación	88508000	1 6
4	cold cartridge	mécanisme eau froide	montura agua fría	94008000	1 10
5	hot cartridge	mécanisme eau chaude	montura agua caliente	94009000	1 10
6	valve set	robinet d'arrêt	válvula completa	88503000	set 17
7	pull rod and knob	tirette	tirador	88541xx0	1 9*
8	3/8 compression fittings (pair)	raccord à bague sertie 3/8 (2 pièces)	tuercas grifería 3/8 (2 pieza)	88513000	set 4
9	connection hose 18"	flexible de raccordement 18"	conexión flexible 18"	88596000	1 7
10	aerator	aérateur	aireador	13912xx0	1 4*
11	Metro handle	poignée Metro	manija Metro	88570xx0	1 11*
	pop-up drain, see p. 4.171	vidage lavabo voir p. 4.171	vaciadores ver p. 4.171	88509xx0	1 12*

hansgrohe

xx = Please see p. 4.1 for finish codes / *PG is for Chrome only. See the index for other finishes.

xx = Description des codes couleur page 4.1 / *PG concerne Chromé seulement. Pour les autres, voir dans la liste des références.

xx = Para el código de acabados ver p. 4.1 / *La PG vale para Cromado solo. Ver el índice para las otras superficies.

4.79

6/2011

Metro

Centerset lavatory faucet / Robinet lavabo / Mezclador para lavabo

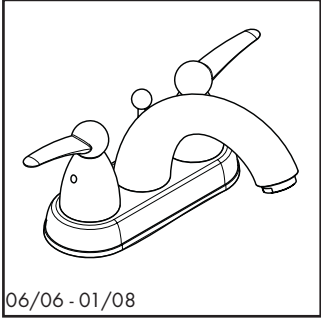

06/06 - 01/08

06437xx0

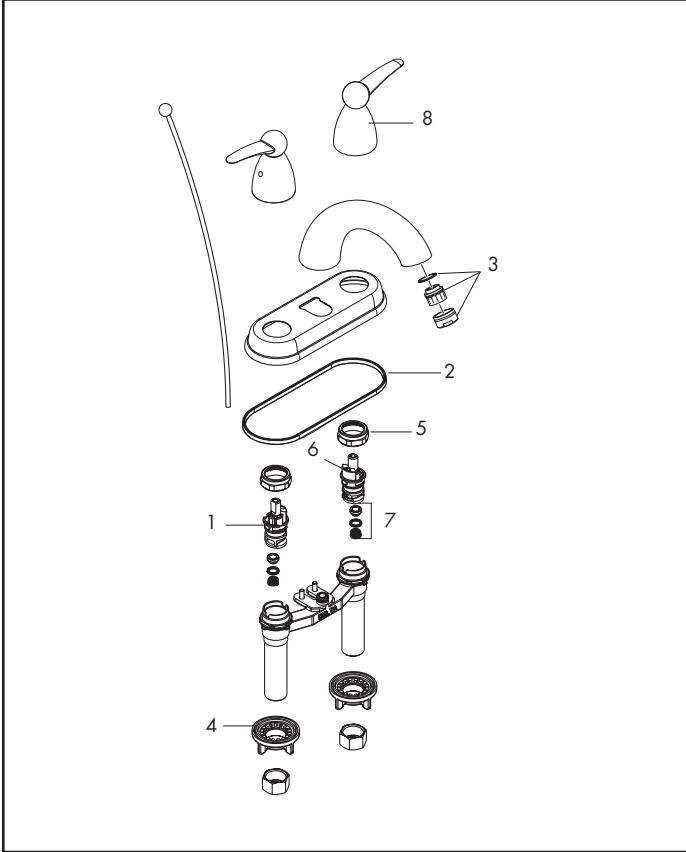

Pos.	Description	Description	Denominación	No./Nr./N°	PG
1	cartridge	cartouche	cartucho	88686000	1 99
2	seal	joint	junta	88687000	1 7
3	aerator	aérateur	aireador	13912xx0	1 4*
4	mounting nut	écrou á six pans	tuerca	88689000	1 99
5	fastening nut	fixation	set de fijación	88690000	1 99
6	¼ turn stop	Butée ¼ de tour	parada a un ¼ de rotación	88691000	1 99
7	seat and spring	set de joints	set de juntas y muelles	88692000	1 99
8	Metro handle	poignée Metro	manija Metro	88698xx0	1 99
	pop-up drain, see p. 4.171	vidage lavabo voir p. 4.171	vaciadores ver p. 4.171	88509xx0	1 12*

xx = Please see p. 4.1 for finish codes / *PG is for Chrome only. See the index for other finishes.
xx = Description des codes couleur page 4.1 / *PG concerne Chromé seulement. Pour les autres, voir dans la liste des références.
xx = Para el código de acabados ver p. 4.1 / *La PG vale para Cromado solo. Ver el índice para las otras superficies.

Swing® C

3-Hole lavatory faucet / Robinet grande ecartement / Batéria americana para lavabo

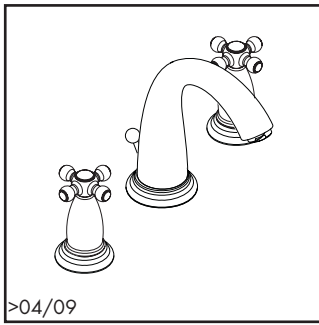

06119xx0

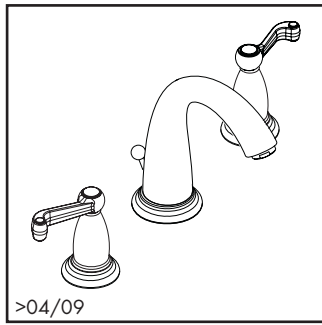

06118xx0

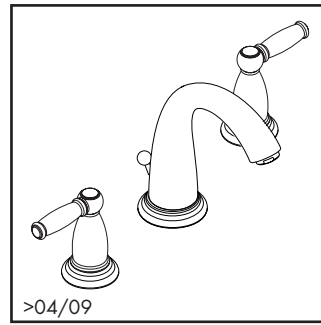

06117xx0

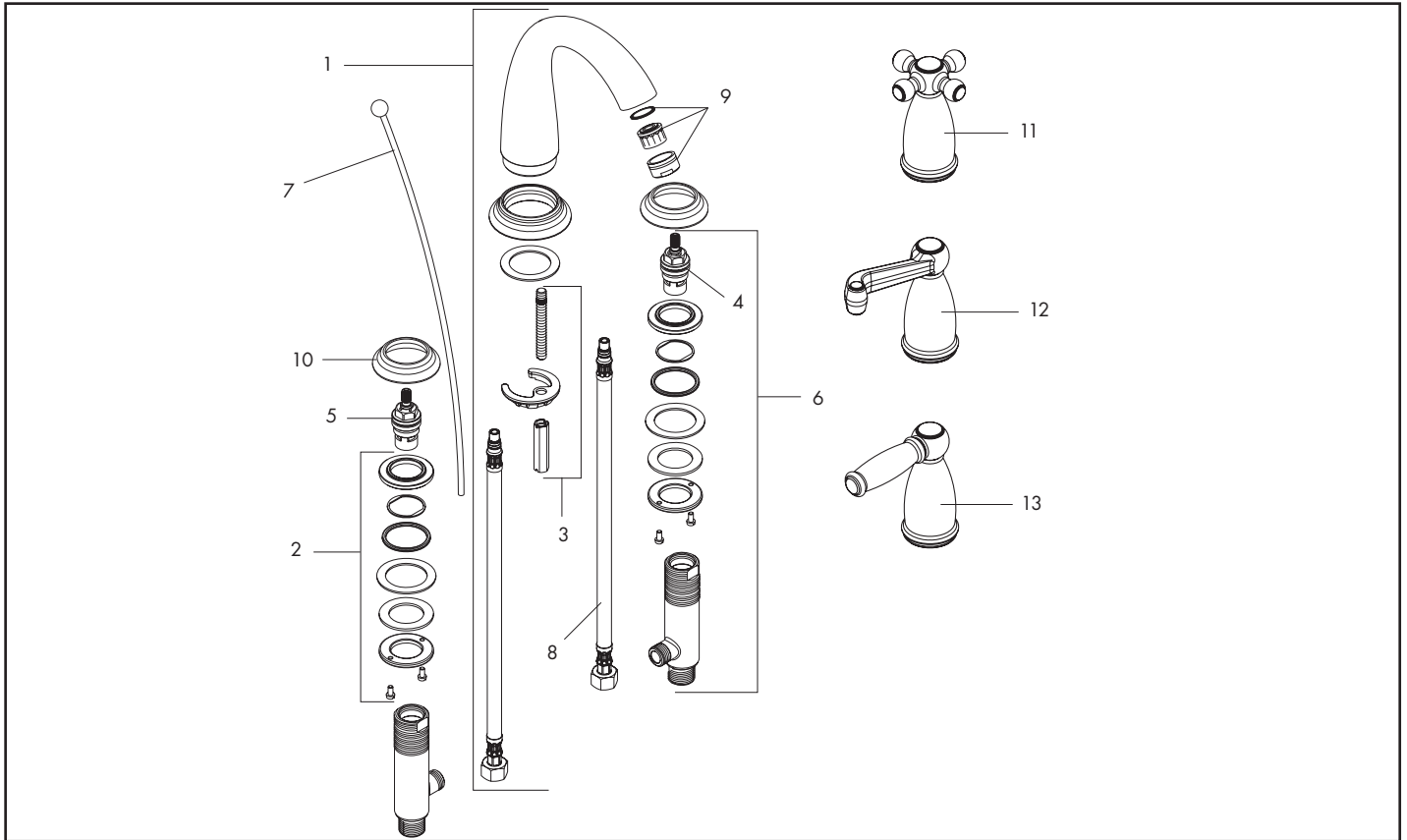

Pos.	Description	Description	Denominación	No./Nr./N°	PG
1	spout	bec	caño	88603xx0	1 17*
2	fixing set	fixation	set de fijación	88511000	1 7
3	fixing set	fixation	set de fijación	88508000	1 6
4	cold cartridge	mécanisme eau froide	montura agua fría	94008000	1 10
5	hot cartridge	mécanisme eau chaude	montura agua caliente	94009000	1 10
6	valve set	robinet d'arrêt	válvula completa	88503000	set 17
7	pull rod and knob	tirette	tirador	88541xx0	1 9*
8	connection hose 18"	flexible de raccordement 18"	conexión flexible 18"	88596000	1 7
9	aerator	aérateur	aireador	88744xx0	1 8*
10	handle deco-ring	rosette pour poignée	florón para manija	88600xx0	1 6*
11	cross handle	poignée croisillon	manija en cruz		1 99
12	scroll hot handle	poignée volute, chaude	manija tipo voluta, caliente	88617xx0	1 14*
	scroll cold handle	poignée volute, froide	manija tipo voluta, fría	88616xx0	1 10*
13	lever handle	poignée levier	manija tipo palanca	88612xx0	1 16*
	pop-up drain, see p. 4.171	vidage lavabo voir p. 4.171	vaciadores ver p. 4.171	88509xx0	1 12*

Swing® C

3-Hole lavatory faucet / Robinet grande écartement / Batéria americana para lavabo

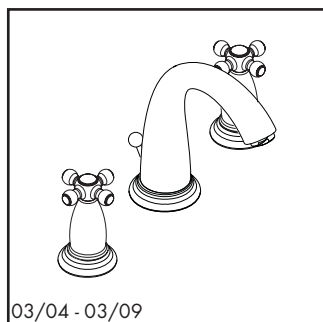

03/04 - 03/09

06119xx0

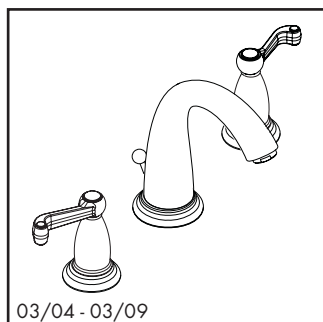

03/04 - 03/09

06118xx0

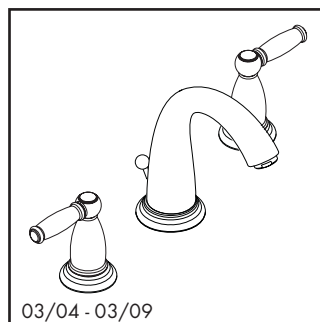

03/04 - 03/09

06117xx0

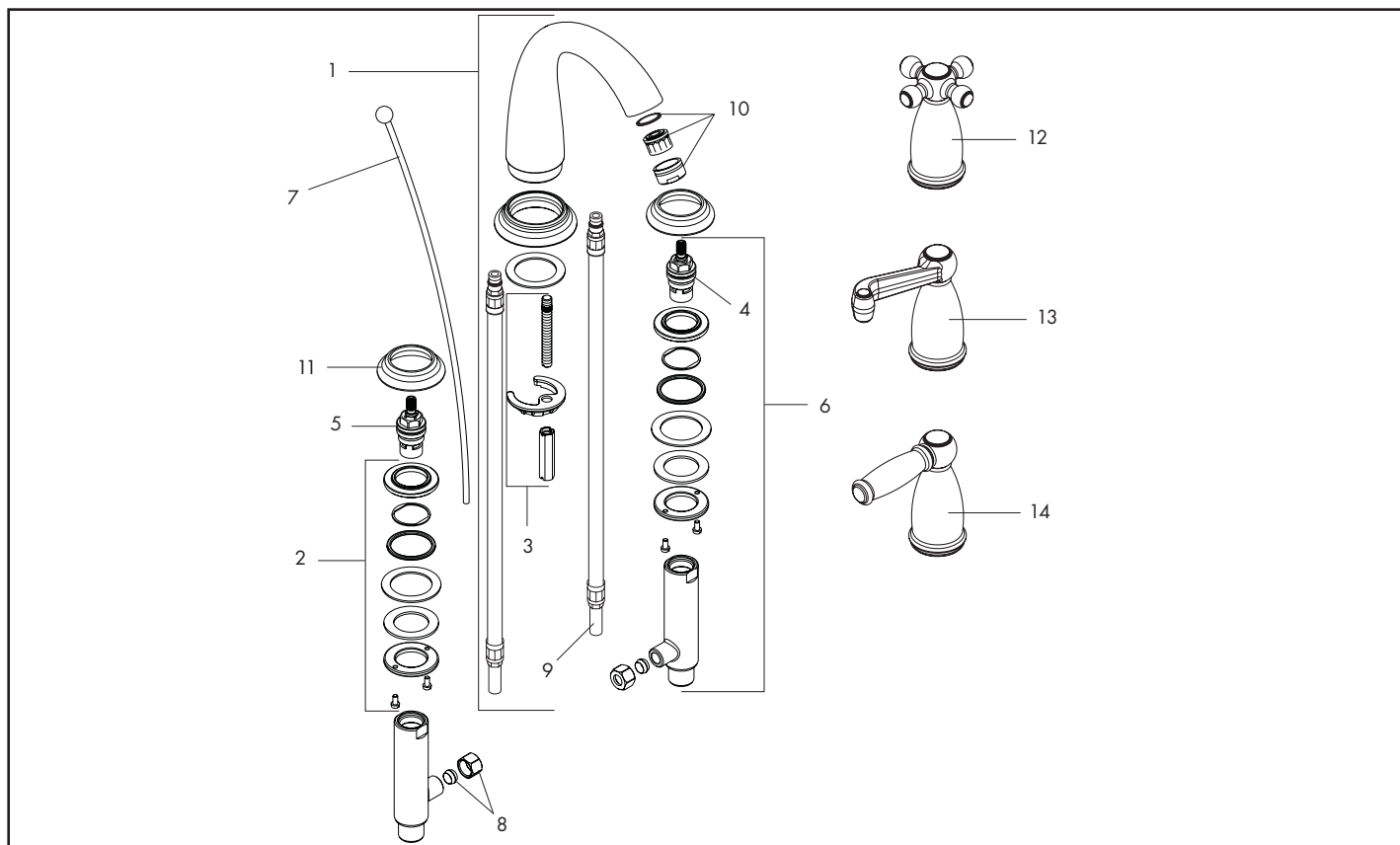

Pos.	Description	Description	Denominación	No./Nr./N°	PG
1	spout	bec	caño	88603xx0	1 17*
2	fixing set	fixation	set de fijación	88511000	1 7
3	fixing set	fixation	set de fijación	88508000	1 6
4	cold cartridge	mécanisme eau froide	montura agua fría	94008000	1 10
5	hot cartridge	mécanisme eau chaude	montura agua caliente	94009000	1 10
6	valve set	robinet d'arrêt	válvula completa	88503000	set 17
7	pull rod and knob	tirette	tirador	88541xx0	1 9*
8	3/8 compression fittings (pair)	raccord à bague sertie 3/8 (2 pièces)	tuercas grifería 3/8 (2 pieza)	88513000	set 4
9	connection hose 18"	flexible de raccordement 18"	conexión flexible 18"	88596000	1 7
10	aerator	aérateur	aireador	13912xx0	1 4*
11	handle deco-ring	rosette pour poignée	florón para manija	88600xx0	1 6*
12	cross handle	poignée croisillon	manija en cruz		1 99
13	scroll hot handle	poignée volute, chaude	manija tipo voluta, caliente	88617xx0	1 14*
	scroll cold handle	poignée volute, froide	manija tipo voluta, fría	88616xx0	1 14*
14	lever handle	poignée levier	manija tipo palanca	88612xx0	1 16*
	pop-up drain, see p. 4.171	vidage lavabo voir p. 4.171	vaciadores ver p. 4.171	88509xx0	1 12*

Tango® C

Centerset lavatory faucet / Robinet lavabo / Mezclador para lavabo

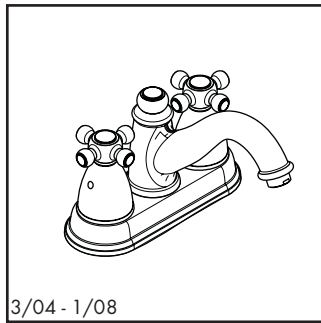

3/04 - 1/08

06430xx0

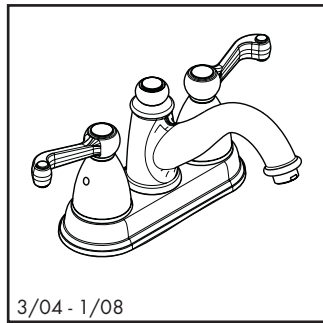

3/04 - 1/08

06431xx0

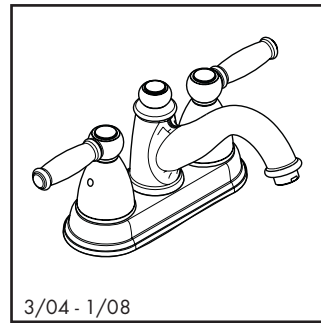

3/04 - 1/08

06432xx0

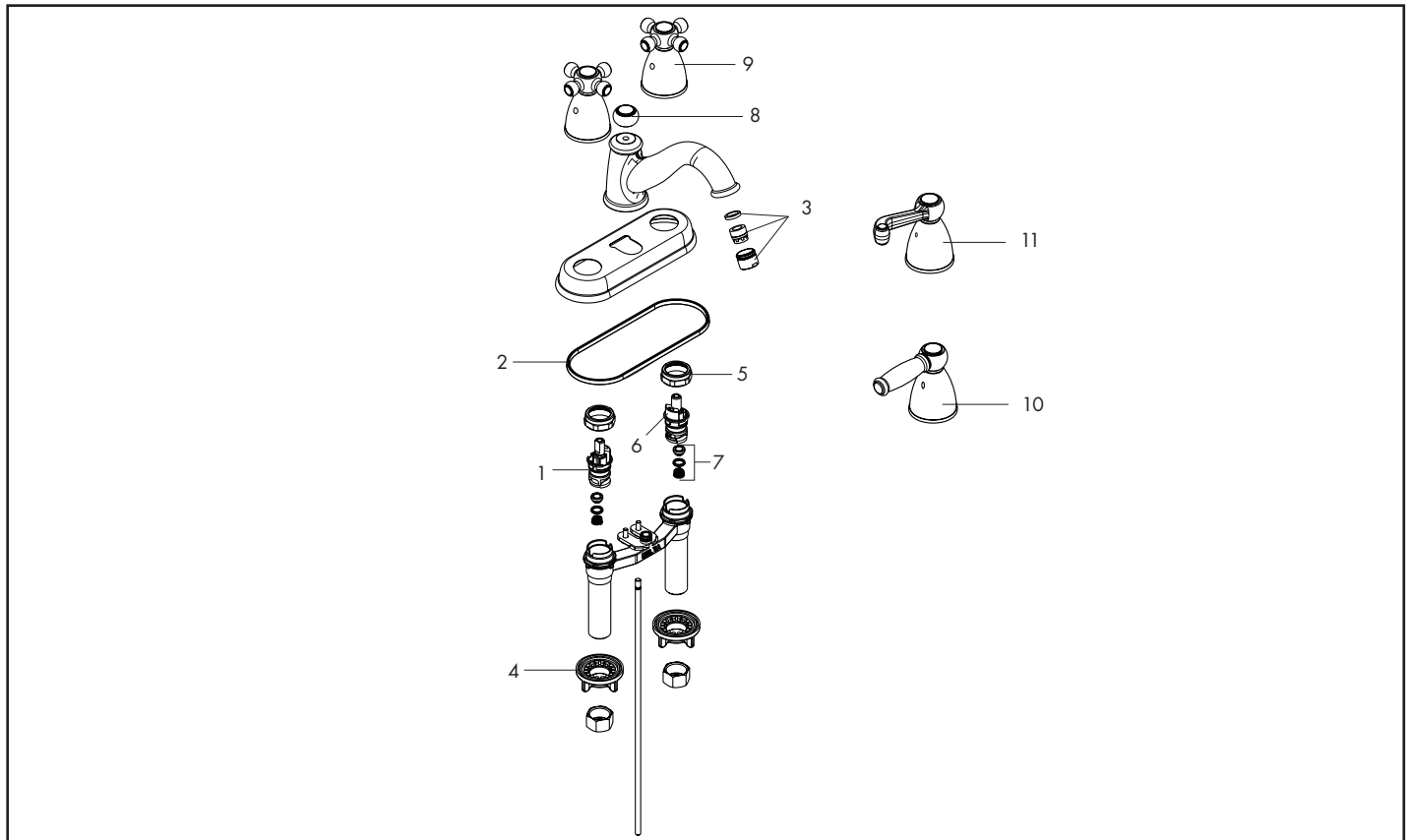

Pos.	Description	Description	Denominación	No./Nr./N°	PG
1	cartridge	cartouche	cartucho	88686000	1 99
2	seal	joint	junta	88687000	1 7
3	aerator	aérateur	aireador	96673xx0	1 10*
4	mounting nut	écrou à six pans	tuerca	88689000	1 99
5	fastening nut	fixation	set de fijación	88690000	1 99
6	stop bushing			88691000	1 99
7	seat and spring	set de joints	set de juntas y muelles	88692000	1 99
8	pull rod knob	bouton	tirador	88688xx0	1 99
9	cross handle	poignée croisillon	manija en cruz	88693xx0	1 99
10	lever handle	poignée levier	manija tipo palanca	88694xx0	1 99
11	scroll hot handle	poignée volute, chaude	manija tipo voluta, caliente	88695xx0	1 99
	scroll cold handle	poignée volute, froide	manija tipo voluta, fría	88696xx0	1 99
	pop-up drain, see p. 4.171	vidage lavabo voir p. 4.171	vaciadores ver p. 4.171	88509xx0	1 12*

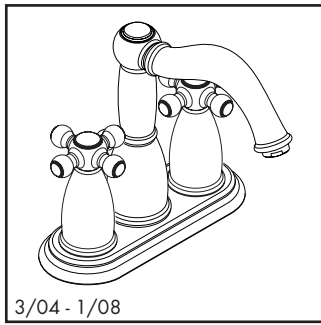

06039xx0

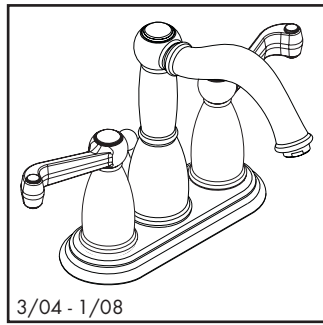

06038xx0

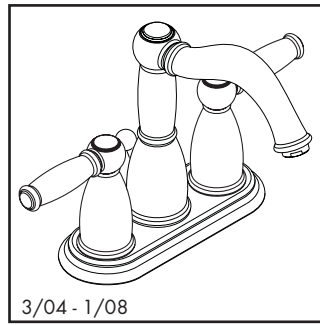

06037xx0

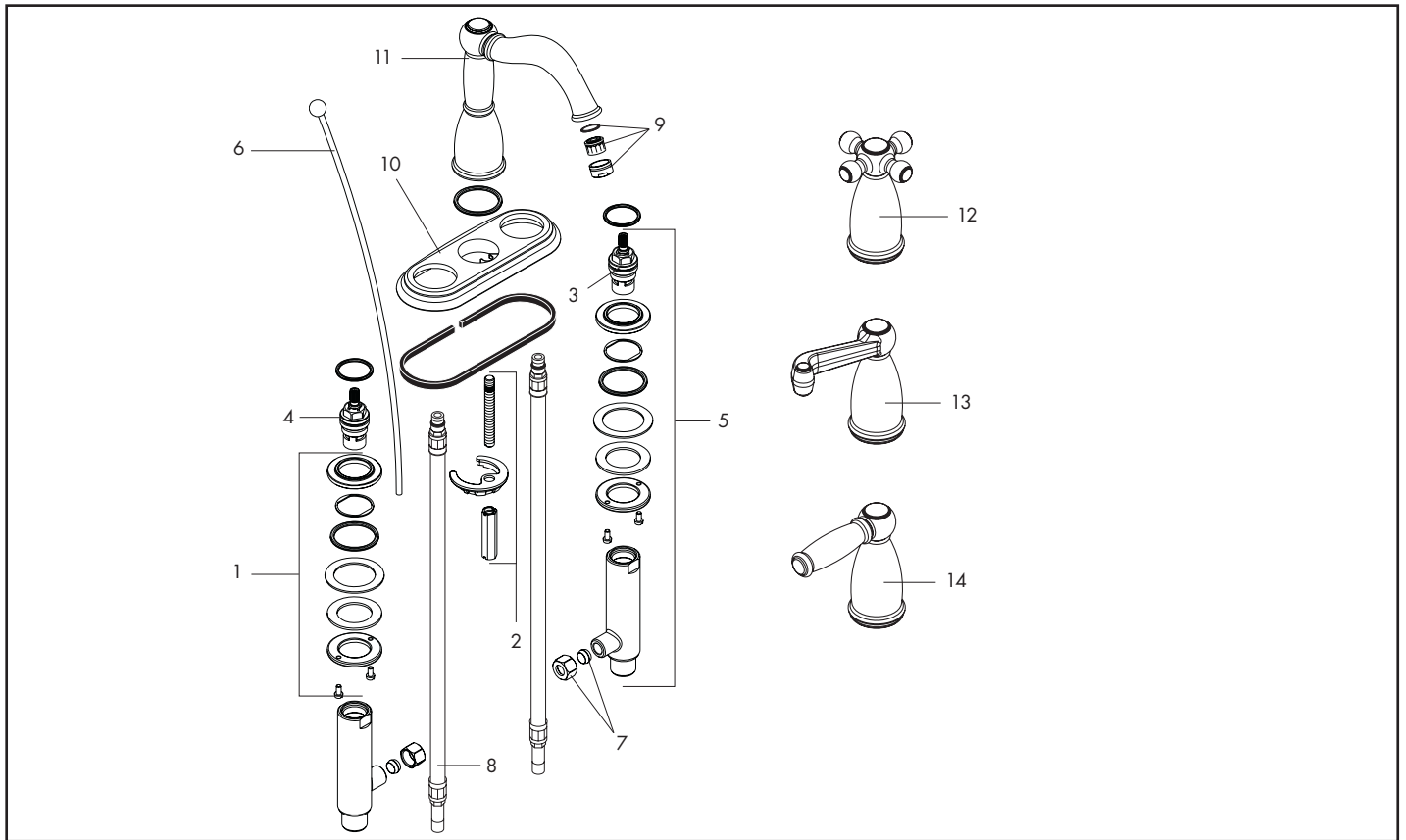

Pos.	Description	Description	Denominación	No./Nr./N°	PG
1	fixing set	fixation	set de fijación	88511000	1 7
2	fixing set	fixation	set de fijación	88508000	1 6
3	cold cartridge	mécanisme eau froide	montura agua fría	94008000	1 10
4	hot cartridge	mécanisme eau chaude	montura agua caliente	94009000	1 10
5	valve set	robinet d'arrêt	válvula completa	88503000	set 17
6	pull rod and knob	tirette	tirador	88541xx0	1 9*
7	3/8" compression fittings (pair)	raccord à bague sertie 3/8" (2 pièces)	tueras grifería 3/8" (2 pieza)	88513000	set 4
8	connection hose 18"	flexible de raccordement 18"	conexión flexible 18"	88596000	1 7
9	aerator	aérateur	aireador	96673xx0	1 10*
10	escutcheon	rosette	florón	88510xx0	1 10*
11	spout	bec	caño	88601xx0	1 17*
12	cross handle	poignée croisillon	manija en cruz		1 99
13	scroll hot handle	poignée volute, chaude	manija tipo voluta, caliente	88617xx0	1 14*
	scroll cold handle	poignée volute, froide	manija tipo voluta, fría	88616xx0	1 14*
14	lever handle	poignée levier	manija tipo palanca	88612xx0	1 16*
	pop-up drain, see p. 4.171	vidage lavabo voir p. 4.171	vaciadores ver p. 4.171	88509xx0	1 12*

Tango® C

3-Hole lavatory faucet / Robinet grande écartement / Batéria americana para lavabo

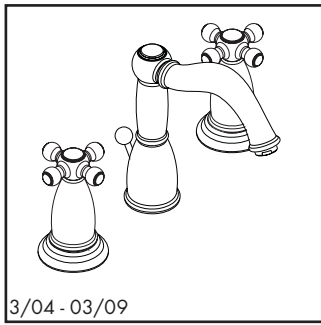

3/04 - 03/09

06042xx0

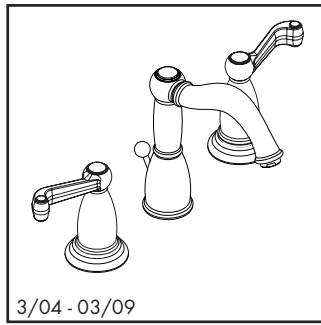

3/04 - 03/09

06041xx0

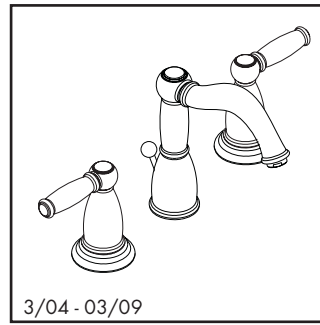

3/04 - 03/09

06040xx0

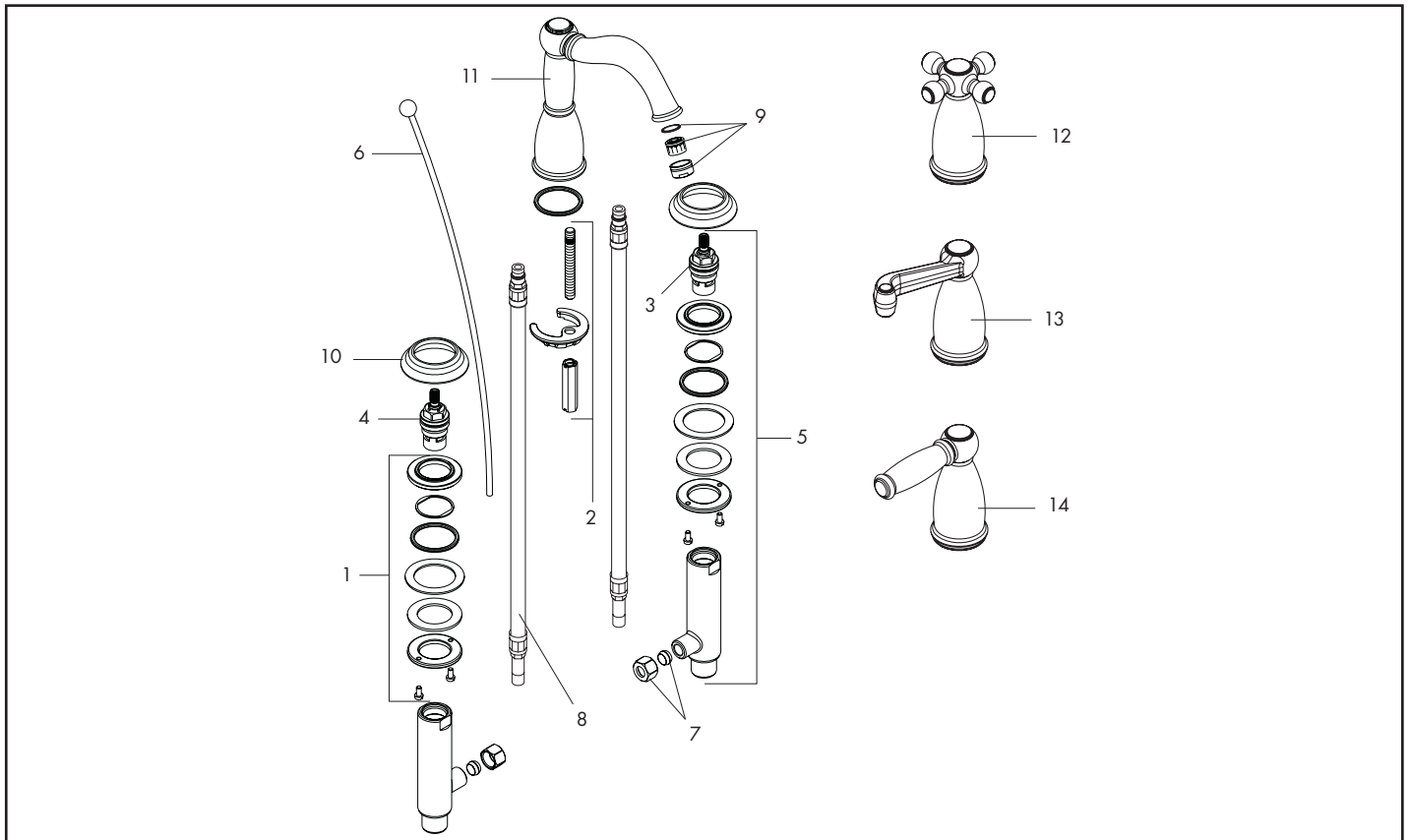

Pos.	Description	Description	Denominación	No./Nr./N°	PG
1	fixing set	fixation	set de fijación	88511000	1 7
2	fixing set	fixation	set de fijación	88508000	1 6
3	cold cartridge	mécanisme eau froide	montura agua fría	94008000	1 10
4	hot cartridge	mécanisme eau chaude	montura agua caliente	94009000	1 10
5	valve set	robinet d'arrêt	válvula completa	88503000	set 17
6	pull rod and knob	tirette	tirador	88541xx0	1 9*
7	3/8 compression fittings (pair)	raccord à bague sertie 3/8 (2 pièces)	tueras grifería 3/8 (2 pieza)	88513000	set 4
8	connection hose 18"	flexible de raccordement 18"	conexión flexible 18"	88596000	1 7
9	aerator	aérateur	aireador	96673xx0	1 10*
10	handle deco-ring	rosette pour poignée	florón para manija	88600xx0	1 6*
11	spout	bec	caño	88601xx0	1 17*
12	cross handle	poignée croisillon	manija en cruz		1 99
13	scroll hot handle	poignée volute, chaude	manija tipo voluta, caliente	88617xx0	1 14*
	scroll cold handle	poignée volute, froide	manija tipo voluta, fría	88616xx0	1 14*
14	lever handle	poignée levier	manija tipo palanca	88612xx0	1 16*
	pop-up drain, see p. 4.171	vidage lavabo voir p. 4.171	vaciadores ver p. 4.171	88509xx0	1 12*

Tango® C

3-Hole lavatory faucet / Robinet grande ecartement / Batéria americana para lavabo

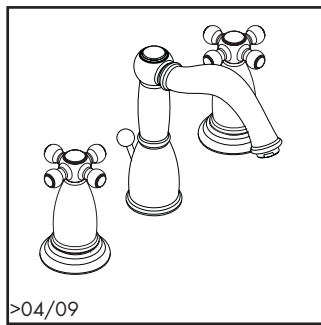

06042xx0

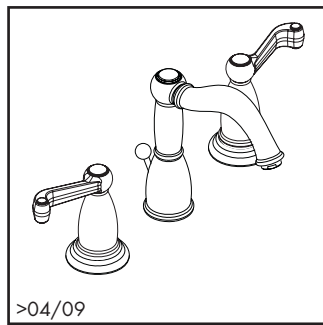

06041xx0

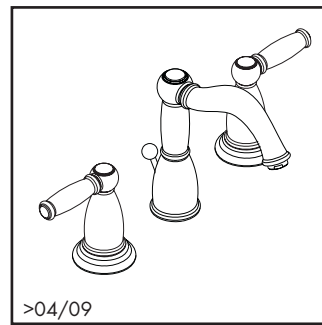

06040xx0

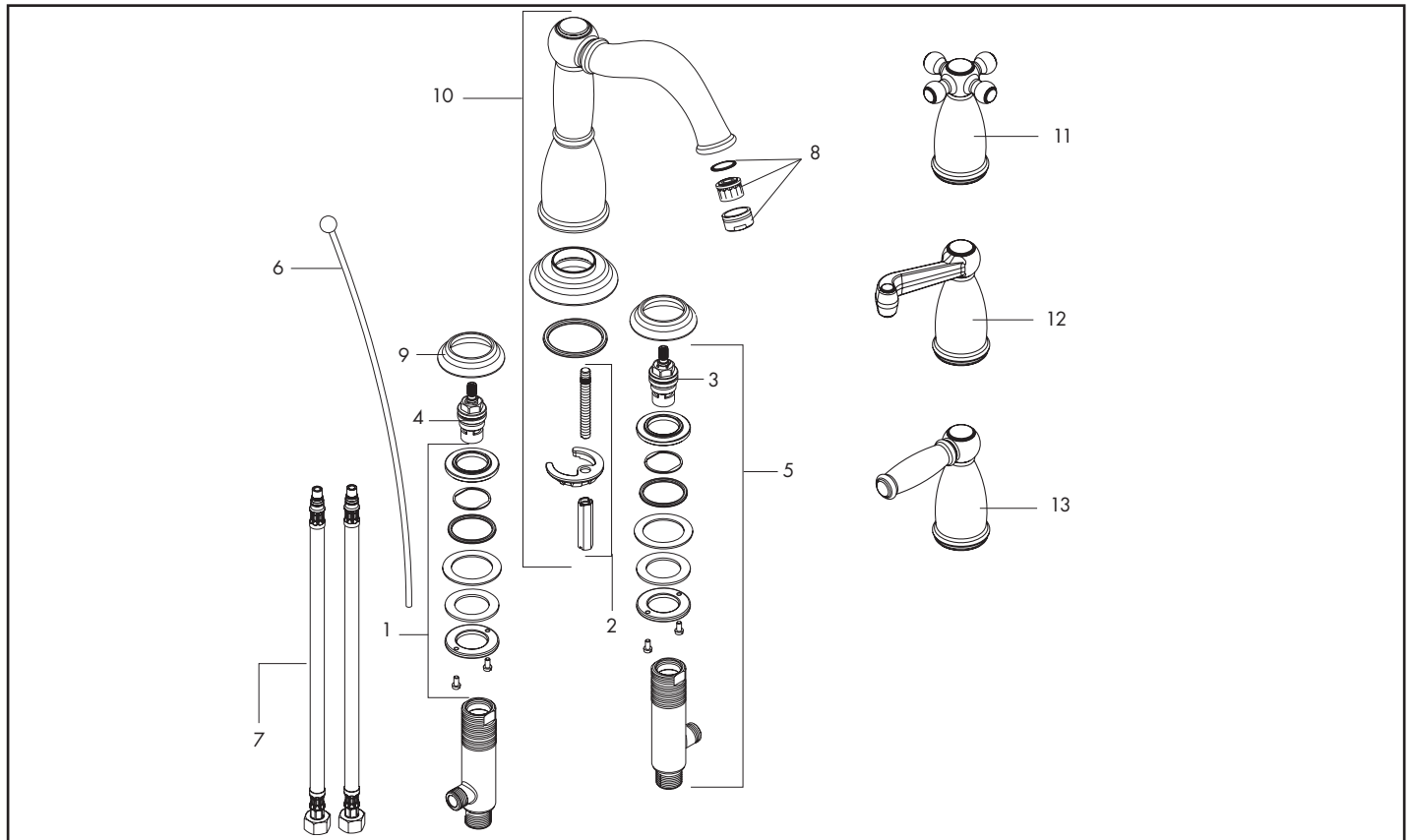

Pos.	Description	Description	Denominación	No./Nr./N°	PG
1	fixing set	fixation	set de fijación	88511000	1 7
2	fixing set	fixation	set de fijación	88508000	1 6
3	cold cartridge	mécanisme eau froide	montura agua fría	94008000	1 10
4	hot cartridge	mécanisme eau chaude	montura agua caliente	94009000	1 10
5	valve set	robinet d'arrêt	válvula completa	88503000	set 17
6	pull rod and knob	tirette	tirador	88541xx0	1 9*
7	connection hose 18"	flexible de raccordement 18"	conexión flexible 18"	88596000	1 7
8	aerator	aérateur	aíreador	88743xx0	1 9*
9	handle deco-ring	rosette pour poignée	florón para manija	88600xx0	1 6*
10	spout	bec	caño	88601xx0	1 17*
11	cross handle	poignée croisillon	manija en cruz		1 99
12	scroll hot handle	poignée volute, chaude	manija tipo voluta, caliente	88617xx0	1 14*
	scroll cold handle	poignée volute, froide	manija tipo voluta, fría	88616xx0	1 14*
13	lever handle	poignée levier	manija tipo palanca	88612xx0	1 16*
	pop-up drain, see p. 4.171	vidage lavabo voir p. 4.171	vaciadores ver p. 4.171	88509xx0	1 12*

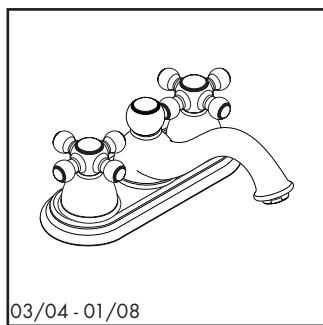

03/04 - 01/08

06103xx0

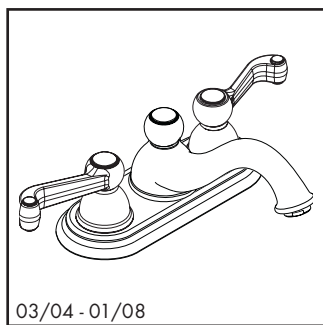

03/04 - 01/08

06102xx0

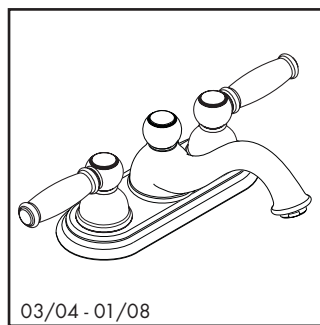

03/04 - 01/08

06101xx0

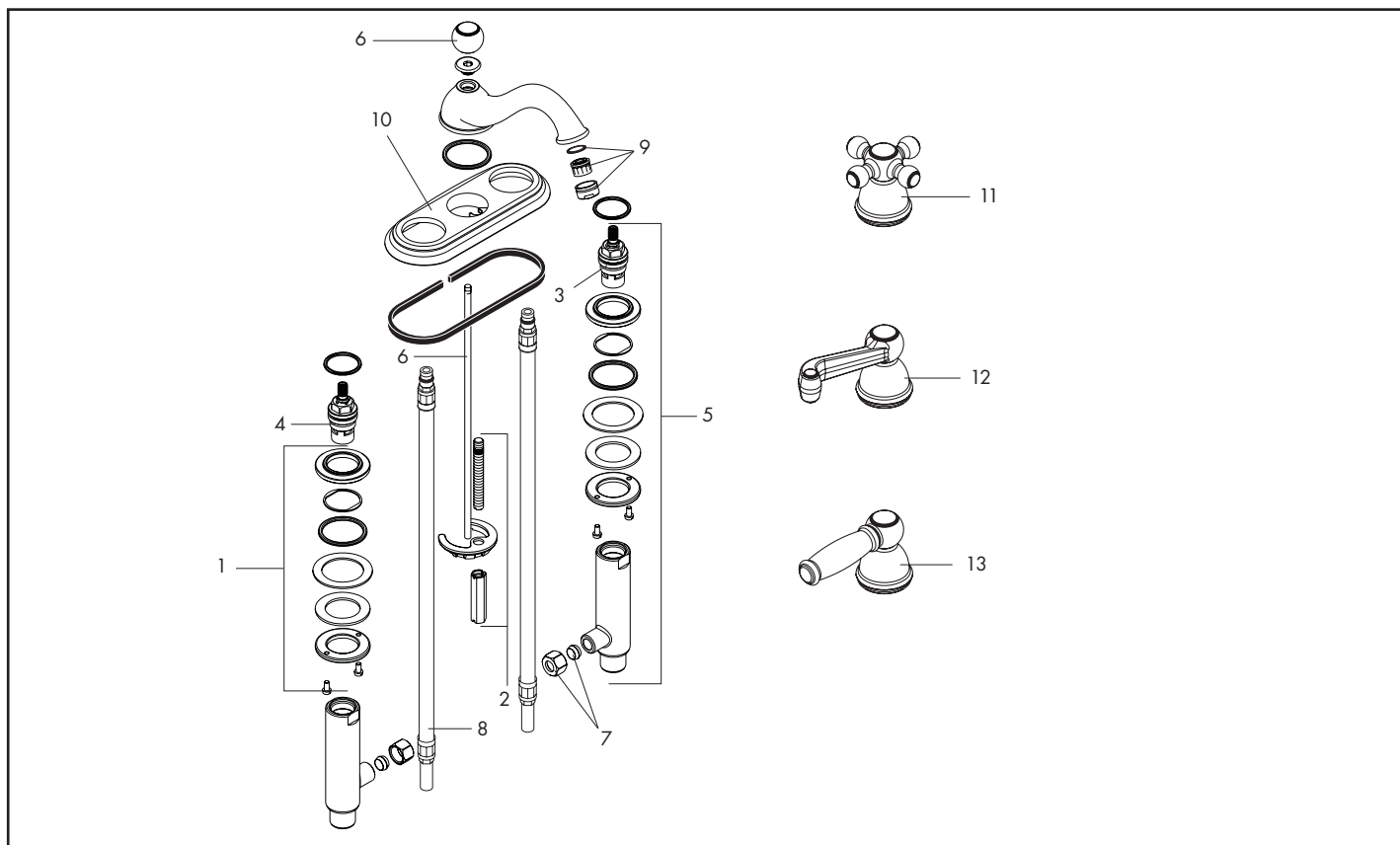

Pos.	Description	Description	Denominación	No./Nr./N°	PG
1	fixing set	fixation	set de fijación	88511000	1 7
2	fixing set	fixation	set de fijación	88508000	1 6
3	cold cartridge	mécanisme eau froide	montura agua fría	94008000	1 10
4	hot cartridge	mécanisme eau chaude	montura agua caliente	94009000	1 10
5	valve set	robinet d'arrêt	válvula completa	88503000	set 17
6	pull rod and knob	tirette	tirador	88541xx0	1 9*
7	3/8 compression fittings (pair)	raccord à bague sertie 3/8 (2 pièces)	tueras grifería 3/8 (2 pieza)	88513000	set 4
8	connection hose 18"	flexible de raccordement 18"	conexión flexible 18"	88596000	1 7
9	aerator	aérateur	aireador	96673xx0	1 10*
10	escutcheon	rosette	florón	88510xx0	1 10*
11	cross handle	poignée croisillon	manija en cruz		1 99
12	scroll hot handle	poignée volute, chaude	manija tipo voluta, caliente		1 99
	scroll cold handle	poignée volute, froide	manija tipo voluta, fría		1 99
13	lever handle	poignée levier	manija tipo palanca	88615xx0	1 14*
	pop-up drain, see p. 4.171	vidage lavabo voir p. 4.171	vaciadores ver p. 4.171	88509xx0	1 12*

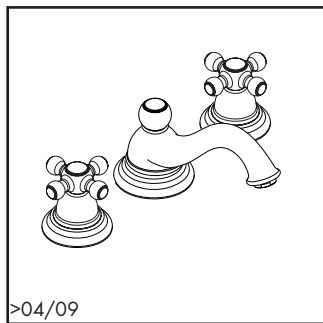

06106xx0

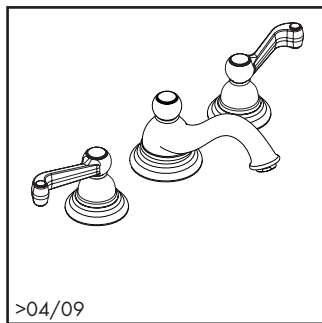

06105xx0

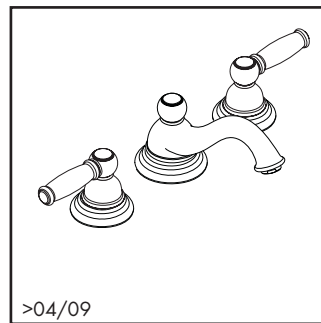

06104xx0

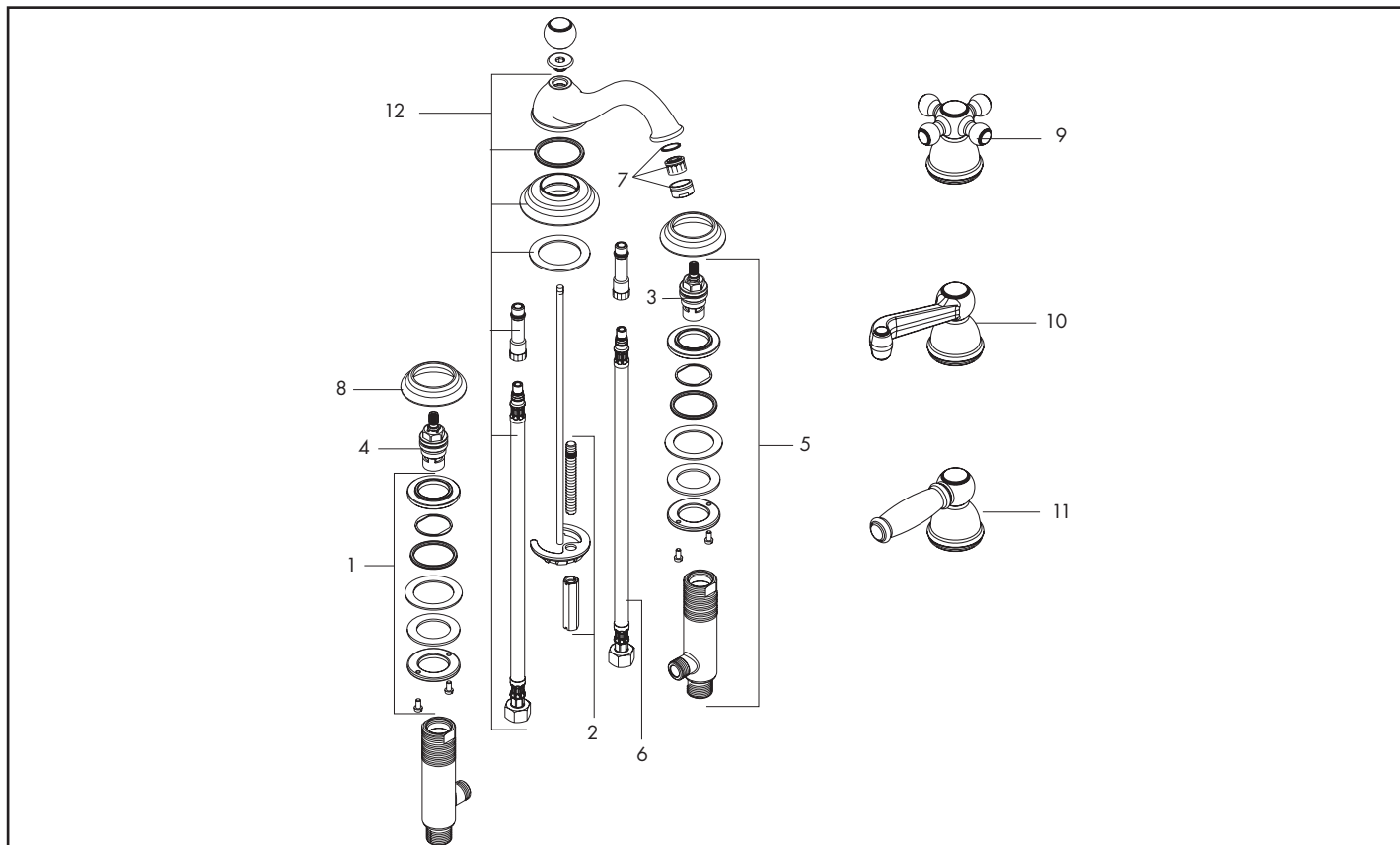

Pos.	Description	Description	Denominación	No./Nr./N°	PG
1	fixing set	fixation	set de fijación	88511000	1 7
2	fixing set	fixation	set de fijación	88508000	1 6
3	cold cartridge	mécanisme eau froide	montura agua fría	94008000	1 10
4	hot cartridge	mécanisme eau chaude	montura agua caliente	94009000	1 10
5	valve set	robinet d'arrêt	válvula completa	88503000	set 17
6	connection hose 18"	flexible de raccordement 18"	conexión flexible 18"	88596000	1 7
7	aerator	aérateur	aireador	88743xx0	1 9*
8	handle deco-ring	rosette pour poignée	florón para manija	88600xx0	1 6*
9	cross handle	poignée croisillon	manija en cruz		1 99
10	scroll hot handle	poignée volute, chaude	manija tipo voluta, caliente		1 99
	scroll cold handle	poignée volute, froide	manija tipo voluta, fría		1 99
11	lever handle	poignée levier	manija tipo palanca	88615xx0	1 14*
12	spout	bec	caño	88602xx0	1 16*
	pop-up drain, see p. 4.171	vidage lavabo voir p. 4.171	vaciadores ver p. 4.171	88509xx0	1 12*

Limbo® C

3-Hole lavatory faucet / Robinet grande ecartement / Batéria americana para lavabo

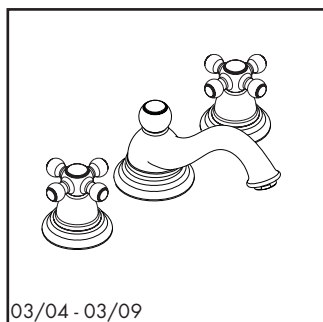

03/04 - 03/09

06106xx0

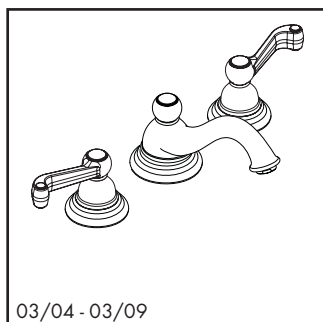

03/04 - 03/09

06105xx0

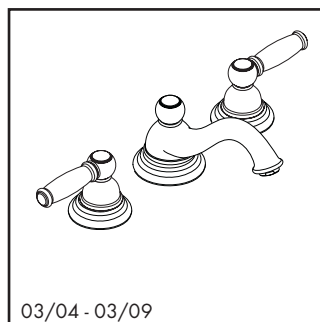

03/04 - 03/09

06104xx0

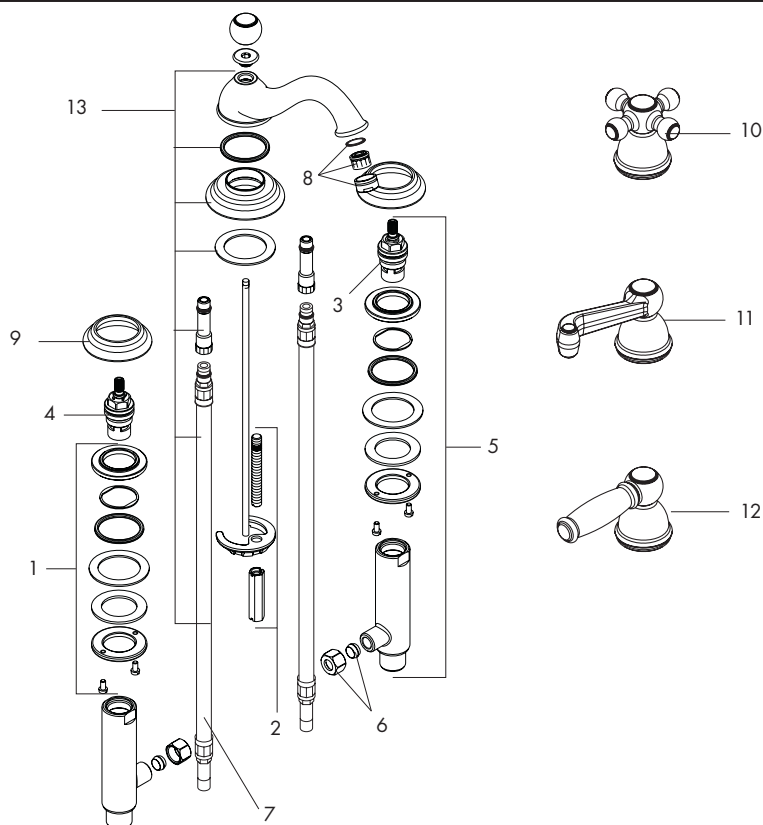

Pos.	Description	Description	Denominación	No./Nr./N°	PG
1	fixing set	fixation	set de fijación	88511000	1 7
2	fixing set	fixation	set de fijación	88508000	1 6
3	cold cartridge	mécanisme eau froide	montura agua fría	94008000	1 10
4	hot cartridge	mécanisme eau chaude	montura agua caliente	94009000	1 10
5	valve set	robinet d'arrêt	válvula completa	88503000	set 17
6	3/8 compression fittings (pair)	raccord à bague sertie 3/8 (2 pièces)	tuercas grifería 3/8 (2 pieza)	88513000	set 4
7	connection hose 18"	flexible de raccordement 18"	conexión flexible 18"	88596000	1 7
8	aerator	aérateur	aireador	96673xx0	1 10*
9	handle deco-ring	rosette pour poignée	florón para manija	88600xx0	1 6*
10	cross handle	poignée croisillon	manija en cruz		1 99
11	scroll hot handle	poignée volute, chaude	manija tipo voluta, caliente		1 99
12	scroll cold handle	poignée volute, froide	manija tipo voluta, fría		1 99
12	lever handle	poignée levier	manija tipo palanca	88615xx0	1 14*
13	spout	bec	caño	88602xx0	1 16*
	pop-up drain, see p. 4.171	vidage lavabo voir p. 4.171	vaciadores ver p. 4.171	88509xx0	1 12*

1901

3-Hole lavatory faucet / Robinet grande ecartement / Batéria americana para lavabo

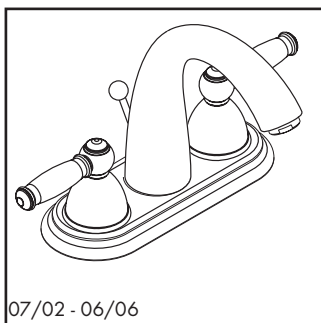

07/02 - 06/06

06608xx0

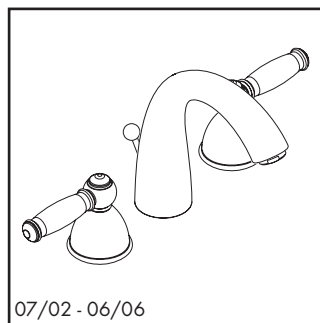

07/02 - 06/06

06609xx0

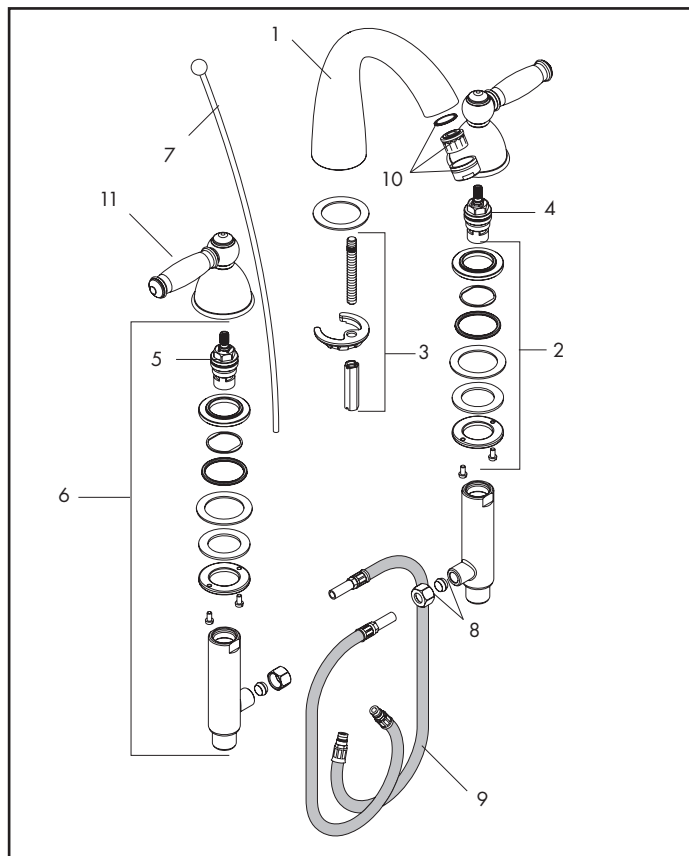
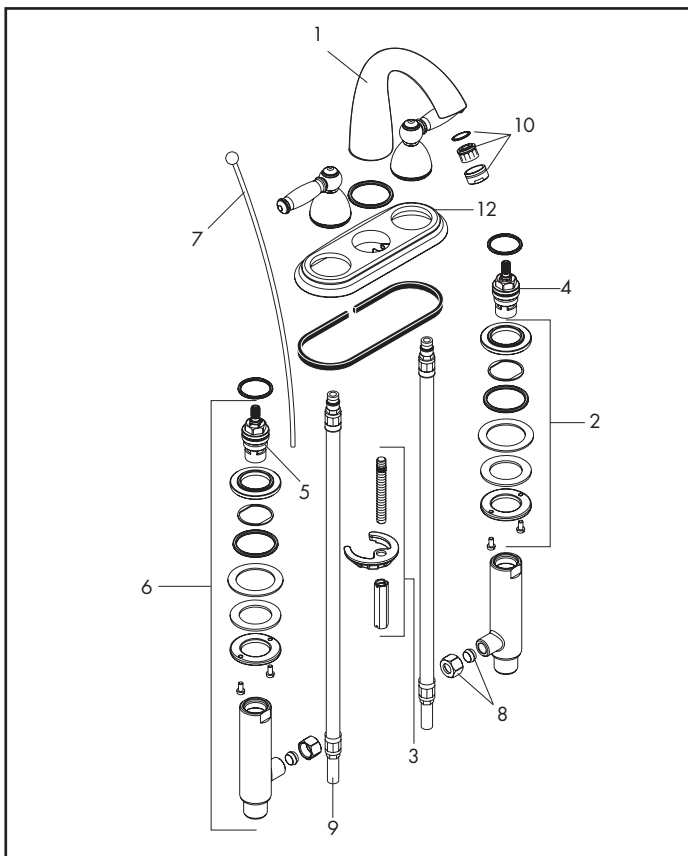

Pos.	Description	Description	Denominación	No./Nr./N°	PG
1	spout	bec	caño	88507xx0	1 16*
2	fixing set	fixation	set de fijación	88511000	1 7
3	fixing set	fixation	set de fijación	88508000	1 6
4	cold cartridge	mécanisme eau froide	montura agua fría	94008000	1 10
5	hot cartridge	mécanisme eau chaude	montura agua caliente	94009000	1 10
6	valve set	robinet d'arrêt	válvula completa	88503000	set 17
7	pull rod and knob	tirette	tirador	88541xx0	1 9*
8	3/8 compression fittings (pair)	raccord à bague sertie 3/8 (2 pièces)	tuercas grifería 3/8 (2 pieza)	88513000	set 4
9	connection hose 18"	flexible de raccordement 18"	conexión flexible 18"	88596000	1 7
10	aerator	aérateur	aireador	13912xx0	1 4*
11	1901 handle	poignée 1901	manija 1901	88572xx0	1 12*
12	escutcheon	rosace	florón	88510xx0	1 10*
	pop-up drain, see p. 4.171	vidage lavabo voir p. 4.171	vaciadores ver p. 4.171	88509xx0	1 12*

Monsoon

3-Hole lavatory faucet / Robinet grande ecartement / Batéria americana para lavabo

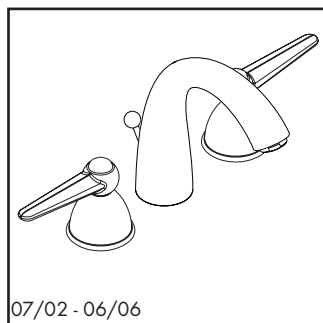

07/02 - 06/06

06673xx0

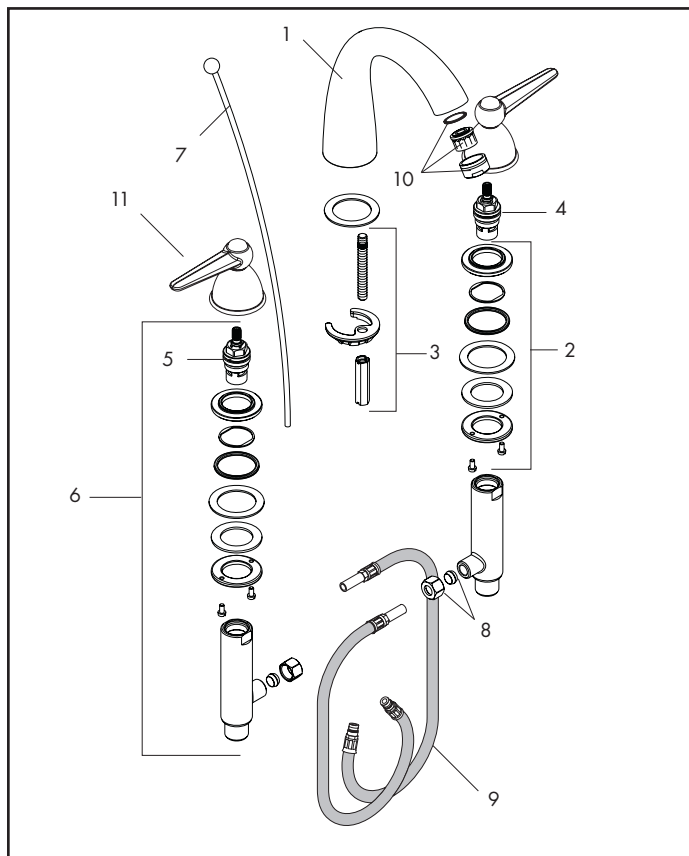

Pos.	Description	Description	Denominación	No./Nr./N°	PG
1	spout	bec	caño	88507xx0	1 16*
2	fixing set	fixation	set de fijación	88511000	1 7
3	fixing set	fixation	set de fijación	88508000	1 6
4	cold cartridge	mécanisme eau froide	montura agua fría	94008000	1 10
5	hot cartridge	mécanisme eau chaude	montura agua caliente	94009000	1 10
6	valve set	robinet d'arrêt	válvula completa	88503000	set 17
7	pull rod and knob	tirette	tirador	88541xx0	1 9*
8	3/8 compression fittings (pair)	raccord à bague sertie 3/8 (2 pièces)	tuercas grifería 3/8 (2 pieza)	88513000	set 4
9	connection hose 18"	flexible de raccordement 18"	conexión flexible 18"	88596000	1 7
10	aerator	aérateur	aireador	13912xx0	1 4*
11	Monsoon handle	poignée Monsoon	manija Monsoon	88573xx0	1 11*
	pop-up drain, see p. 4.171	vidage lavabo voir p. 4.171	vaciadores ver p. 4.171	88509xx0	1 12*

Stratos

Centerset lavatory faucet / Robinet lavabo / Mezclador para lavabo

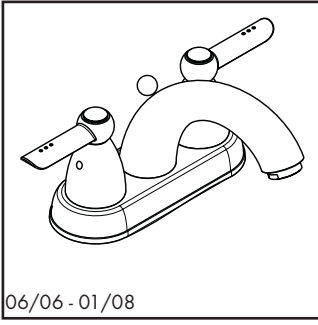

06436xx0

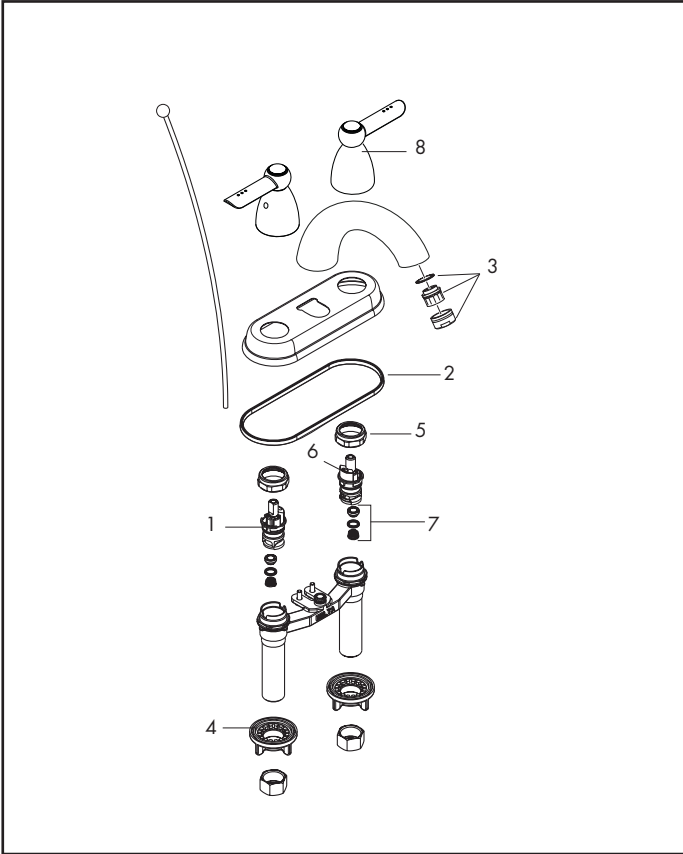

Pos.	Description	Description	Denominación	No./Nr./N°	PG
1	cartridge	cartouche	cartucho	88686000	1 99
2	seal	joint	junta	88687000	1 7
3	aerator	aérateur	aireador	13912xx0	1 4*
4	mounting nut	écrou à six pans	tuerca	88689000	1 99
5	fastening nut	fixation	set de fijación	88690000	1 99
6	1/4 turn stop	butée 1/4 de tour	parada a un 1/4 de rotación	88691000	1 99
7	seat and spring	set de joints	set de juntas y muelles	88692000	1 99
8	Stratos handle	poignée Stratos	manija Stratos	88698xx0	1 99
	pop-up drain, see p. 4.171	vidage lavabo voir p. 4.171	vaciadores ver p. 4.171	88509xx0	1 12*

Stratos

3-Hole lavatory faucet / Robinet grande ecartement / Batéria americana para lavabo

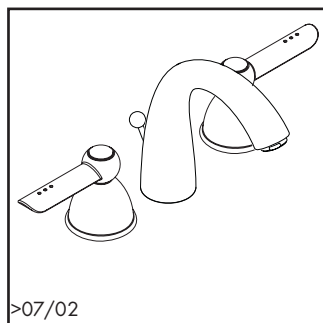

>07/02

06577xx0

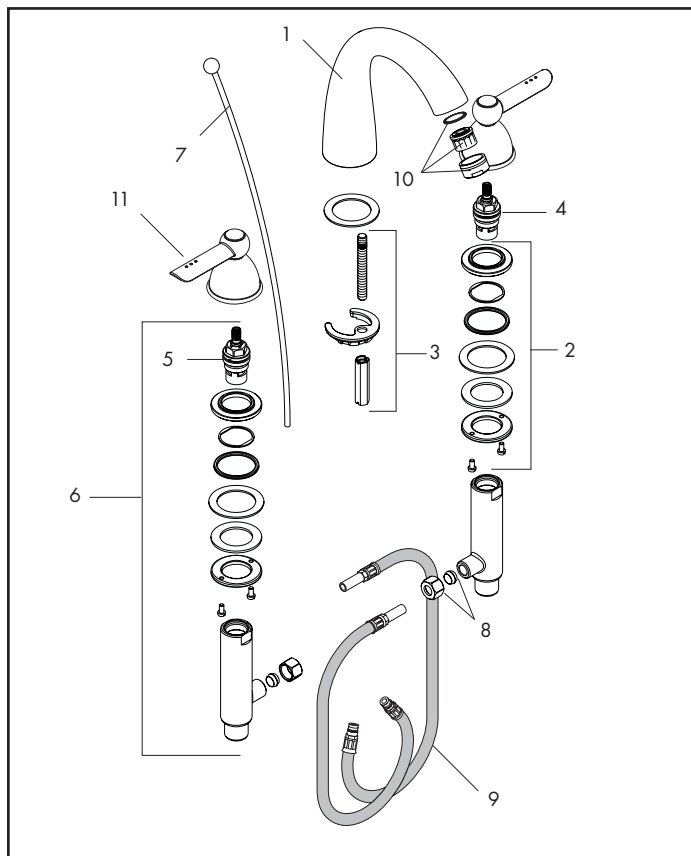

Pos.	Description	Description	Denominación	No./Nr./N°	PG
1	spout	bec	caño	88507xx0	1 16*
2	fixing set	fixation	set de fijación	88511000	1 7
3	fixing set	fixation	set de fijación	88508000	1 6
4	cold cartridge	mécanisme eau froide	montura agua fría	94008000	1 10
5	hot cartridge	mécanisme eau chaude	montura agua caliente	94009000	1 10
6	valve set	robinet d'arrêt	válvula completa	88503000	set 17
7	pull rod and knob	tirette	tirador	88541xx0	1 9*
8	3/8 compression fittings (pair)	raccord à bague sertie 3/8 (2 pièces)	tuerca grifería 3/8 (2 pieza)	88513000	set 4
9	connection hose 18"	flexible de raccordement 18"	conexión flexible 18"	88596000	1 7
10	aerator	aérateur	aireador	13912xx0	1 4*
11	Stratos handle	poignée Stratos	manija Stratos	88571xx0	1 11*
	pop-up drain, see p. 4.171	vidage lavabo voir p. 4.171	vaciadores ver p. 4.171	88509xx0	1 12*

Interaktiv S

3-Hole lavatory faucet / Robinet grande ecartement / Bat eria americana para lavabo

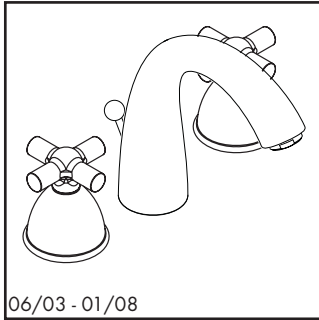

06874xx0

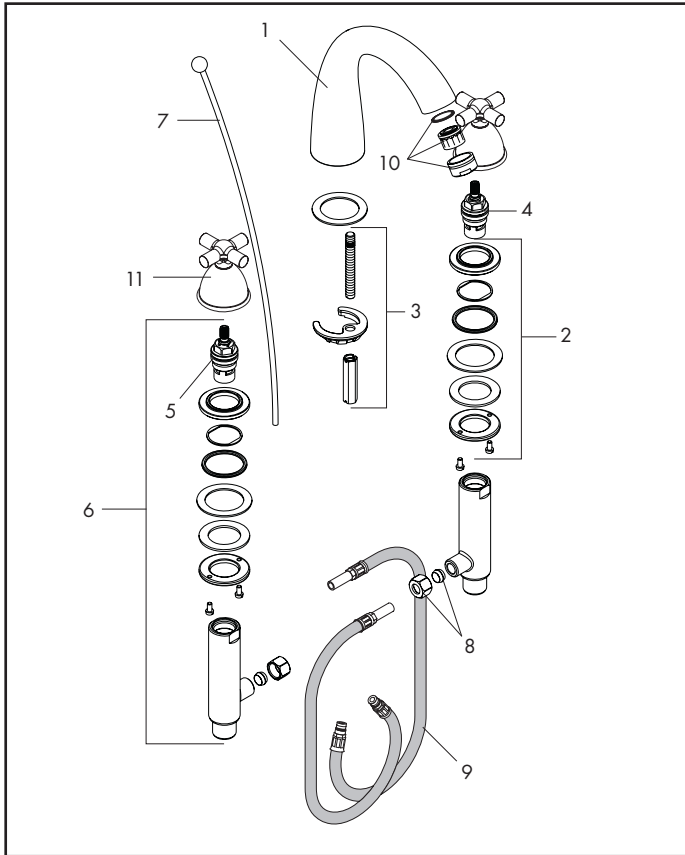

Pos.	Description	Description	Denominaci�n	No./Nr./N�	PG
1	spout	bec	ca�o	88507xx0	1 16*
2	fixing set	fixation	set de fijaci�n	88511000	1 7
3	fixing set	fixation	set de fijaci�n	88508000	1 6
4	cold cartridge	m�canisme eau froide	montura agua fr�a	94008000	1 10
5	hot cartridge	m�canisme eau chaude	montura agua caliente	94009000	1 10
6	valve set	robinet d'arr�t	v�lvula completa	88503000	set 17
7	pull rod and knob	tirette	tirador	88541xx0	1 9*
8	3/8 compression fittings (pair)	raccord � bague sertie 3/8 (2 pi�ces)	tuercas grifer�a 3/8 (2 pieza)	88513000	set 4
9	connection hose 18"	flexible de raccordement 18"	conexi�n flexible 18"	88596000	1 7
10	aerator	a�rateur	aireador	13912xx0	1 4*
11	Interaktiv S handle	poign�e Interaktiv S	manija Interaktiv S		99
	pop-up drain, see p. 4.171	vidage lavabo voir p. 4.171	vaciadores ver p. 4.171	88509xx0	1 12*